

Panasonic

DSS Console

Quick Reference Guide

Model No. **KX-T7740**

Important Information

When using the KX-T7740, keep the following in mind.

- If there is any trouble, disconnect the DSS Console from the telephone line and have it repaired.
- Keep the unit away from heating appliances and electrical noise generating devices such as fluorescent lamps and motors.
- The unit should be kept free of dust, moisture and vibration, and it should not be exposed to direct sunlight.
- Do not use benzine, thinner, or the like, or any abrasive powder to clean the cabinet. Wipe it with a soft cloth.
- Do not disassemble this unit. Dangerous electrical shock could result. The unit must only be disassembled and repaired by qualified service technicians.
- When a failure occurs which exposes any internal parts, disconnect the telephone line cord immediately, and return the unit to your maintainer.

WARNING:

TO PREVENT THE RISK OF FIRE OR ELECTRIC SHOCK, DO NOT EXPOSE THIS PRODUCT TO RAIN OR ANY TYPE OF MOISTURE.

Note:

In this manual, the suffix of each model number is omitted.

Please read this manual before using, and save for future reference.

When you ship the product

Carefully pack and send it prepaid, adequately insured and preferably in the original carton. Attach a postage-paid letter, detailing the symptom to the outside of the carton.

DO NOT send the product to the Executive or Regional Sales offices. They are NOT equipped to make repairs.

Product service

Panasonic Factory Servicers for this product are listed in the servicer directory. Consult your authorized Panasonic dealer for detailed instructions.

Included Accessories: for extra orders, call toll free 1-800-332-5368

Telephone Line Cord	1
Stand	1
Attachment Plate	1
Screws	2

Location of Controls

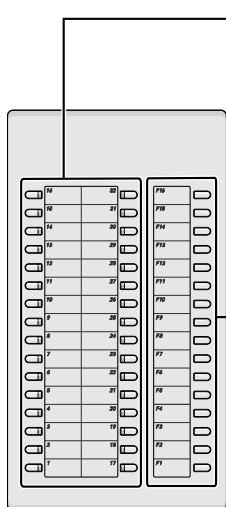

DSS Buttons with Busy Lamp Field (BLF):

To access an extension, simply press the DSS button. The BLF indicates the current status of the corresponding extension. These buttons can also be assigned for one-touch dialing.

Function Buttons:

You can access various functions with one touch once the buttons are programmed.

For programming, refer to the user manual of the main unit.

Connection

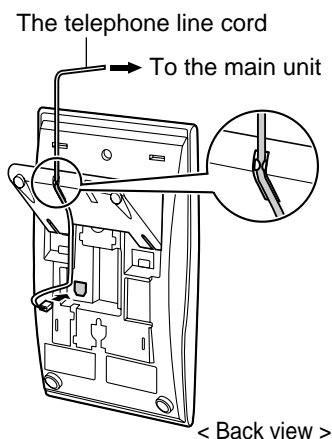

The KX-T7740 DSS Console should always be used in conjunction (side by side) with a Panasonic proprietary telephone (e.g., KX-T7720, KX-T7730, KX-T7735, KX-T7750) for proper operation. The devices must be associated through programming. For programming, consult your dealer.

CAUTION

Ensure the cord is inserted in the groove to prevent damage to the connector.

Attaching a Proprietary Tele-

This unit can be connected to a Panasonic proprietary telephone (e.g., KX-T7720, KX-T7730, KX-T7735, KX-T7750). Use the enclosed plate and screws.

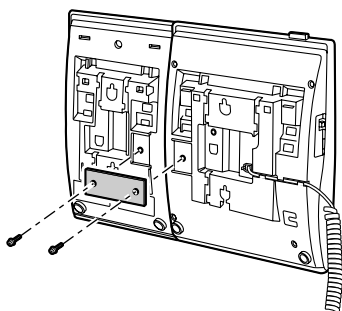

Wall Mounting

This unit can be mounted on a wall.

- 1 Remove the attached stand.

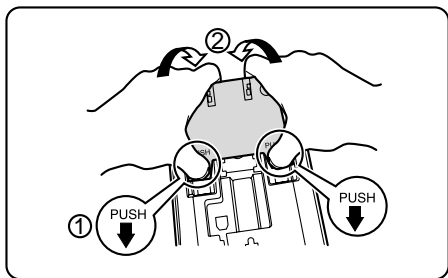

- 2 Mount the unit on the wall.

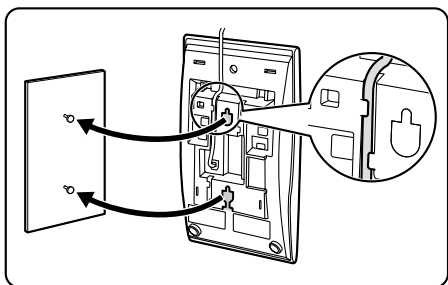

Important Safety Instructions

When using this unit, basic safety precautions should always be followed to reduce the risk of fire, electric shock, or personal injury.

1. Read and understand all instructions.
2. Follow all warnings and instructions marked on this unit.
3. Unplug this unit from the main unit before cleaning. Do not use liquid or aerosol cleaners. Use a damp cloth for cleaning.
4. Do not use this unit near water, for example, near a bathtub, washbowl, kitchen sink, or the like.
5. Place this unit securely on a stable surface. Serious damage and/or injury may result if the unit falls.
6. Do not cover slots and openings on the unit. They are provided for ventilation and protection against overheating. Never place the unit near radiators, or in a place where proper ventilation is not provided.
7. Do not allow anything to rest on the extension cord. Do not locate this unit where the cord will be abused by persons walking on it.
8. Do not overload wall outlets and extension cords. This can result in the risk of fire or electric shock.
9. Never push any objects through slots in this unit. This may result in the risk of fire or electric shock. Never spill any liquid on the unit.
10. To reduce the risk of electric shock, do not disassemble this unit. Take the unit to an authorized servicer when service is required. Opening or removing covers may expose you to dangerous voltages or other risks. Incorrect reassembly can cause electric shock when the unit is subsequently used.
11. Unplug this unit from the main unit, and refer servicing to an authorized servicer when the following conditions occur:
 - A. When the extension cord is damaged or frayed.
 - B. If liquid has been spilled into the unit.
 - C. If the unit has been exposed to rain or water.

Important Safety Instructions

- D. If the unit does not work normally by following the manual. Adjust only controls covered by the manual. Improper adjustment may require extensive work by an authorized servicer.
 - E. If the unit has been dropped, or physically damaged.
 - F. If the unit exhibits a distinct change in performance.
12. During thunderstorms, avoid using telephones except cordless types. There may be a remote risk of an electric shock from lightning.
13. Do not use this unit to report a gas leak, when in the vicinity of the leak.

SAVE THESE
INSTRUCTIONS

FCC Information

NOTE:

This equipment has been tested and found to comply with the limits for a Class B digital device, pursuant to Part 15 of the FCC Rules. These limits are designed to provide reasonable protection against harmful interference in a residential installation. This equipment generates, uses, and can radiate radio frequency energy and, if not installed and used in accordance with the instructions, may cause harmful interference to radio communications. However, there is no guarantee that interference will not occur in a particular installation. If this equipment does cause harmful interference to radio or television reception, which can be determined by turning the equipment off and on, the user is encouraged to try to correct the interference by one or more of the following measures:

- Reorient or relocate the receiving antenna.
- Increase the separation between the equipment and receiver.
- Connect the equipment into an outlet on a circuit different from that to which the receiver is connected.
- Consult the dealer or an experienced radio/TV technician for help.

CAUTION:

To assure continued compliance with FCC rules, do not make any unauthorized modifications. When programming emergency numbers and/or making test calls to emergency numbers:

- 1) Remain on the line, and briefly explain to the dispatcher the reason for the call before hanging up.
- 2) Perform such activities in the off- peak hours, such as early morning hours or late evenings.

For your future reference

SERIAL NO. _____

(found on the bottom of the unit)

DATE OF PURCHASE _____

NAME OF DEALER _____

DEALER S ADDRESS _____

DEALER S TEL. NO. _____

**Panasonic Consumer Electronics Company,
Division of Matsushita Electric Corporation of
America**

One Panasonic Way, Secaucus,
New Jersey 07094

www.panasonic.com

**Panasonic Sales Company ("PSC"),
Division of Matsushita Electric of Puerto Rico, Inc.**

Ave. 65 de Infantería, Km. 9.5,
San Gabriel Industrial Park, Carolina,
Puerto Rico 00985

© 2002 Kyushu Matsushita Electric Co., Ltd.

All Rights Reserved.