

Meridian Digital Telephones

M3901
M3902
M3903
M3904

User Guide



M3900 Series Meridian Digital Telephone	1
M3901	1
M3902	2
M3903	2
M3904	3
Your Telephone's Controls	5
Terms you should know	9
Your telephone call features	11
Use handsfree calling (M3902, M3903, and M3904)	11
Activate/deactivate Group listening controls	13
Use the Redial list on the M3903	14
Use the Redial list on the M3904	15
Use the Predial feature	16
Make a call	17
Make a call while on-hook	18
Make a call with the dial pad	18
Auto Dial	18
Activate Ring Again	19
Redial last number called	20
Use Speed Call	21
Make a System Speed Call	22
Use Hot Line	22
Make an Intercom call	23
Answer a call	24
While on an active call	25
Place a call on Hold	25
Transfer a call	25
Use Timed Reminder Recall	26
Use Attendant Recall	27
Use Call Park	28

Record a Calling Party Number	29
Display incoming calls	31
Trace a Malicious call	31

Incoming calls **33**

Activate Automatic Answerback	33
Activate Call Pickup	34
Use Call Waiting	35

While you are away from your desk **37**

Call Forward	37
Call Forward - Internal	37
Use Remote Call Forward	38
Secure your telephone	40

Talk with more than one person **42**

Join a call	42
Set up a Conference call	42
Selectable Conferee display and Disconnect	43
Use Group Call	44

Work without interruption **46**

Activate Make Set Busy	46
------------------------------	----

Additional Call Features **47**

Auto Dial Transfer Feature	47
Use the buzz signal	47
Call Page (Connect) to make an announcement	48
Centrex/Exchange Switchhook Flash	48
Charge a call or Charge a Forced call	49
Enhanced Override Feature	51
Forced Camp-on feature	51
On Hold on Loudspeaker	52
Override Feature	54
Privacy Release Feature	54
Radio Page Feature	54
Voice Call Feature	56

Hospitality features	58
Automatic Wake-Up	58
Message Registration	59
Maid Identification	61
Room Status	62
Telephone display (M3902, M3903, and M3904)	65
M3902 display area	65
M3903 display area	65
M3904 display area	66
Use your Options Key (M3902, M3903, M3904)	67
Options feature list	67
Select options	67
Select a language	69
Change a feature key label	69
Contrast adjustment	71
Volume adjustment	72
Choose Ring type	73
Set Call log option (M3903 and M3904)	74
Use Preferred name match (M3904)	74
Use Live dial pad (M3904)	74
Area code setup	75
Set Call timer	75
Format time and date	76
Set Key click	76
Use Headset port on call (M3904)	77
Use Headset External Alerter and Recorder Interface (M3903 and M3904)	77
Call indicator light	78
On-hook default path	78
Display diagnostics	78
Activate Group listening	79
Set Meridian Communications Adapter controls	79

Directory display and controls (M3903 and M3904)	80
M3903 Directory display and controls	80
Access your Call Log or Redial List application (M3903)	80
M3904 Directory display and controls	81
Access your Call Log, Redial or Personal Directory application (M3904) ..	81
Directory password protection (M3904)	82
Call Log (M3903 and M3904)	85
Access and use the Call Log (M3903)	85
Access and use the Call Log (M3904)	86
Redial List (M3903 and M3904)	87
Use the Redial List (M3903)	87
Use the Redial List (M3904)	87
Personal Directory (M3904)	88
The Directory Display and Controls (M3904 only)	88
Add a Personal Directory entry	89
Save number from incoming call to Personal Directory	91
Delete or edit an entry	91
Delete your Personal Directory	93
Use the Directory to make a call (M3904)	94
Use Card View	94
Copy a number from the Redial list to the Personal Directory (M3904)	95
Operate the main features on the M3901	97
M3901 Fixed Keys	97
Use a programmed feature or an Auto Dial (M3901)	98
To use Auto Dial (M3901)	100
Use Speed Call (M3901)	100
Use Call Transfer (M3901)	101
Use Conference Call feature (M3901)	102
Activate Ring Again (M3901)	102
Make a call (M3901)	103
Receive a call (M3901)	104
Feature Activation Indicator (M3901)	105

Message and Call Status Indicator (M3901)	105
Accessories for the M3900 Series telephone	107
Accessory Connection Module (ACM)	107
Analog Terminal Adapter (ATA)	107
External Alerter and Recorder Interface	107
Headsets	107
Key-based Expansion Module	107
Meridian Communications Adapter (MCA)	108
Meridian 1 Flexible Feature Codes (FFC)	109
Meridian SL-100 Feature Access Codes (FAC)	110

M3900 Series Meridian Digital Telephone

There are five models in the M3900 Series Meridian Digital Telephone Portfolio. This document describes the M3901, M3902, M3903, and M3904 features and how to use them. The M3902, M3903, and M3904 are described in the main portion of this document. The M3901 is described in a separate section of this document. For information on the M3905 refer to the M3905 Call Center Meridian Digital Telephone User Guide.

M3901

The M3901 has one Line Key and can have five programmable features.

M3901

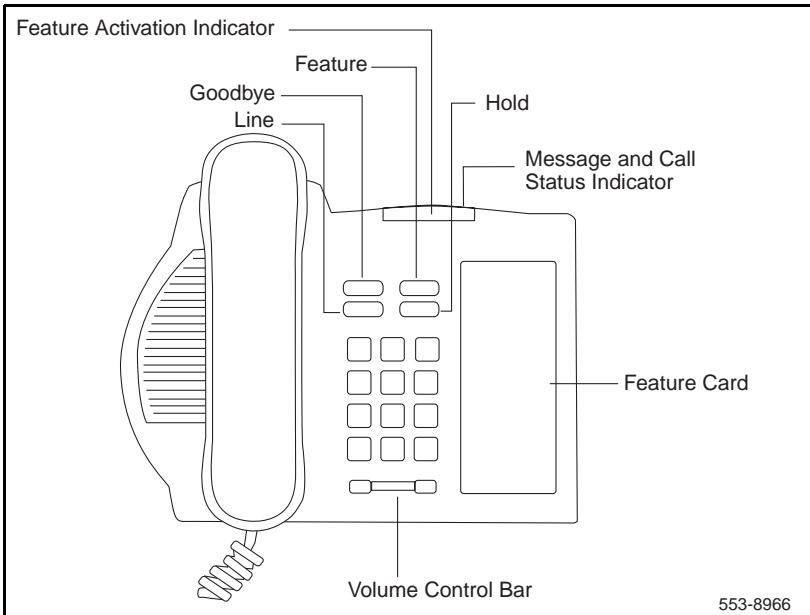

Note: The Meridian SL-100 configures the Line Key as a Directory Number only.

M3902

The M3902 has one Line (DN) Key, and three Programmable Feature Keys (Self-labeled).

M3902

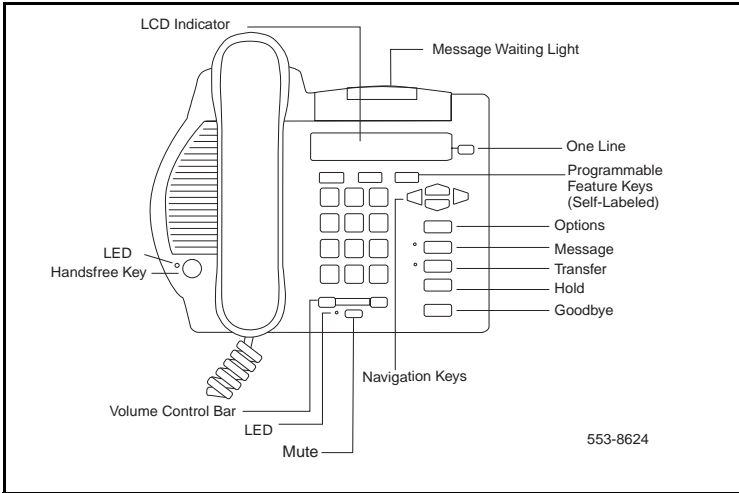

M3903

The M3903 has two Programmable Line/Feature Keys (Self-labeled) with two features or lines configured on each key. It also has four Programmable Feature Keys (Self-labeled) with three features on each key.

M3903

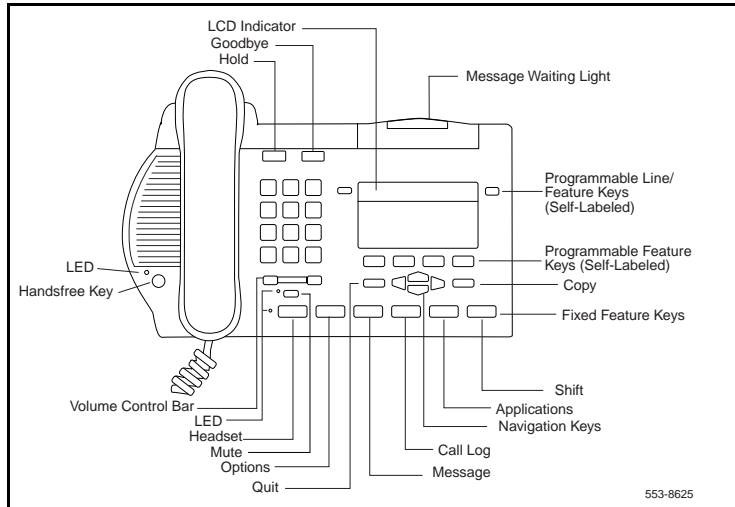

M3904

The M3904, has six Programmable Line/Feature Keys (Self-labeled), with two features or lines configured on each key. It also has four Programmable Feature Keys (Self-labeled) with three features on each key.

M3904

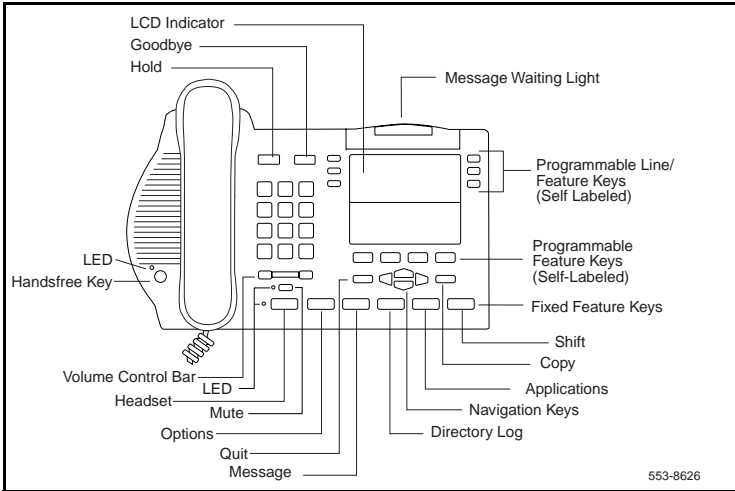

Your Telephone's Controls



Use the **Volume Control Bar** to control the volume of the handset, headset, speaker, ringer, and handsfree. Increase the volume by pressing the right side of the bar. Lower it by pressing the left side.



You can terminate an active call by pressing the **Goodbye Key**. The **Goodbye Key** is useful for disconnecting a handsfree call.



Press the **Headset Key** to answer a call while on the headset or to switch a call from handset or handsfree to the headset.

2498



A steady LCD indicator appearing beside a **Line (DN) Key** means that the feature or line is active. A flashing LCD indicator means the line is on hold or the feature is being programmed.



By pressing the **Hold Key**, you can put an active call on hold. Return to the caller by pressing the DN Key beside the flashing indicator.



The **Speaker Key** allows you to activate the handsfree (M3902, M3903, and M3904) and Group listening features (M3903 and M3904). The speaker LED lights to indicate handsfree is active, the LED flashes to indicate Group listening is active.



The **Mute Key** allows you to listen to the party(ies) whom you are speaking without them hearing you. This is especially useful when you only want to listen on a conference call. Press the Mute Key again to return to a two way conversation. The **Mute Key** applies to handsfree, handset, and headset microphones. The Mute LED flashes when the Mute option is in use.



The **Navigation** Keys allow you to scroll through Menus and lists in the display area.



The **Copy** Key copies incoming or outgoing call numbers into the Personal Directory.



The **Quit** Key ends an active application. Pressing the **Quit** Key does not affect the status of the calls currently on your telephone.

Note: If you press the Quit Key before the Done Key you exit the Options without saving changes. Press the Done Key to exit and save the changes.



The **Options** Key allows you to access and modify telephone options.



The Directory Number (DN) Key is assigned to your telephone. It can be a primary DN, secondary DN, multiple appearance DN, etc.



The lower right hand Line/Feature Key is your **Primary Directory Number** Key (M3902, M3903, M3904). When you pick up the handset, the line associated with this key is ready for you to make a call.



Note: You have only one Primary Directory Number assigned to your telephone. You can have additional Directory Number (DN) Key assigned to your M3903 and M3904 telephone.



The **Dial** Key functions much like the primary Directory Number (DN) Key. The **Dial** Key is used to dial numbers stored in the Directory and Callers List (M3903 and M3904).

Dial



Edit



Delete



Directory/Log



Call Log



Redial



↑ Shift



More...



Trans

Example:



The **Edit** Key is used to edit Directory and Callers List entries (M3904).

The **Delete** Key is used to delete entries or characters in applications.

The **Directory/Log** Key allows you to access Personal Directory, the Call Log and the Redial list (M3904).

The **Call log** Key records the last 100 incoming calls (M3904) or 10 incoming calls (M3903). The Redial list records the last 10 outgoing calls (M3904) or 5 outgoing calls (M3903).

The **Redial** Key appears on the M3904, after pressing the Directory/Log Key, and allows you to go directly into the Redial list.

Note: The Redial List is part of the Directory/Log and Call Log access. On the M3903 you press the Call Log, then scroll to the Redial list and press the Select Key. On the M3904 the Redial Key appears after you have pressed the Directory/Log Key.

The **Shift** Key allows you to access the second layer of the Programmable Line/Feature Keys.

The **More** Key allows you to access the next layer of the Programmable Feature Keys.

Programmable Feature Keys (Self-labeled) are configured for various features on the M3902, M3903, or M3904 Telephones. The **Programmable Feature** Keys are located below the display area. These keys have an LCD label above them that changes based on the active application.

2498



Programmable Line/Feature Keys are configured as a Line (DN) or as a Feature Key (M3903 or M3904). They are located at the sides of the upper display area. Once configured these **Programmable Line/Feature** Keys provide a one touch step to activate a feature. A status icon represents Call and Feature status.

Terms you should know

Attendant — The attendant is a telephone operator in your organization.

Call log— The Call Log is capable of storing unanswered and answered incoming calls. These entries can be accessed through your directory menu.

Call party information—When your telephone rings, the display shows Caller Line Identification (CLID) information. The system must have CLID enabled. The display module shows the phone number and name of the inbound call.

Card View — The Card View displays a directory entry name and telephone number.

Copy Key — The Copy Key allows the M3904 to copy information from one application to the Personal Directory.

Date/time display feature —The Date/time display feature shows the month and date when the telephone is in an idle state.

Directory Number (DN) — The Directory Number is a number that consists of one to seven digits for a telephone. Also known as an extension number.

Feature display—The display area shows status information about the feature in use. It also displays the name and status of the active session.

Feature Access Codes (FAC)—The Feature Access Codes access your telephone's features instead of a fixed feature or soft feature key. Feature Access Codes are available for the Meridian SL-100 system only. For your convenience, the FACs for your system can be printed on a page located at the back of this guide.

Flexible Feature Codes (FFCs) —The Flexible Feature Codes (FFCs) access your telephone's features instead of a fixed feature or soft feature key. Flexible Feature Codes are available for the Meridian 1 system only. For your convenience, the FFCs for your system can be printed on a page located at the back of this guide.

Fixed key—The Fixed Keys are the hard labeled keys on your telephone.

Indicator status —The status indicator can be an LCD or LED that indicates the status of a feature by the flash, wink, steady on, or off of the LCD or LED indicator.

Information line —The Information line of the display relates call information or application information.

Information display—The Information screen displays call activity, lists, prompts, and status of calls.

Interrupted dial tone—Interrupted dial tone is a broken or pulsed dial tone, heard when you access some of the features on your telephone.

Meridian 1 — The Meridian 1 is your office communications system.

More... — The More Key allows access to the multiple layers of the Programmable Feature Keys. These keys are three or four keys located below the lower display area.

Off-hook — Off-hook is a term used to indicate that the telephone is active and ready to make a call. A telephone becomes off hook when you pick up the handset or press the Line (DN) Key.

Paging tone—Paging tone is a special tone heard when using the Radio Paging feature. You hear two beeps followed by dial tone.

Personal Directory —The Personal Directory stores entries by name and phone number.

Primary Directory Number— The Primary Directory Number is the main extension number on your telephone. It is referred to by the Primary Directory Number (PDN) Key.

Private Line — Private Line can be assigned to your telephone. With this line, you can reach an outside number without dialing a code to access an outside line. Internal extensions cannot be dialed from a private line.

Redial list— The Redial list is one of the M3900 series directory. It lists outgoing call numbers. These number can be accessed through your directory menu.

Ringback/ring tone— The Ringback/ring tone is the sound you hear when a call you have made is ringing at its destination.

Shared Directory Numbers — A shared directory number is a DN (extension) that is shared by two or more persons.

Special dial tone— The special dial tone refers to three consecutive tones followed by dial tone that you hear when accessing some of your telephone features.

Switchhook — The switchhook is the button which the handset presses down, disconnecting your call when you replace the handset. The handset when lifted releases the switchhook and you either answer an incoming call or you receive dial tone so you can make a call.

Your telephone call features

Your system administrator assigns features to your programmable feature keys. Whenever this guide describes a procedure that requires special codes ask your system administrator to provide these to you.

To access a feature, you press a Feature Key, or enter a Flexible Feature Code (FFC) or Feature Access Codes (FAC) for the Meridian SL-100. Your system administrator supplies you with Flexible Feature Codes or Feature Access Codes.

Note: In order to use a feature described in this section, your system software must support the feature and the feature must be assigned to your telephone. Check with your system administrator for more details.

Use handsfree calling (M3902, M3903, and M3904)

If your telephone is a M3902, M3903, or M3904 you can use the built-in microphone and speaker instead of the handset for a handsfree call. While on an active call, you can switch between Handset and Handsfree mode.

To answer a call with handsfree:



Press the **Handsfree** Button. You are now on a handsfree call.

To discontinue a handsfree call:



Press the **Goodbye** Key to end the call.

To mute a handsfree call:



1. Press the **Mute** Key. The LED indicator flashes.



2. Press the **Mute** Key again to return to a two way handsfree conversation.

To switch from handsfree to handset:

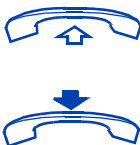

1. Lift the **handset** to switch from handsfree to handset.

2. Replace the **handset** to end the call.

To switch from handset to handsfree:



1. Press the **Handsfree** Button.
2. Replace the **handset**.
3. Press the **Goodbye** Key to end the call.

To use headset:



Connect headset to the headset jack or the handset jack depending on the headset type and the telephone you are using.

Press the **Headset** Key (M3903 and M3904). For the M3902 read the instructions that came with your recommended headset.

Note 1: There are amplified and unamplified headsets that are compatible with your M3900 Series Telephones. Refer to Hardware Options for recommended headset types for your telephone.

Note 2: Use the Option Headset volume adjustment to adjust the gain that works best with the headset type you are using.

To switch from handsfree to headset:



Connect headset or put headset on.

Press the Headset Key (M3903 and M3904). For the M3902 read the instructions for the headset you are using.

Note: A Headset Key is used to switch between the headset and the handset mode of operation (M3903 and M3904). The LED lights steady to indicate you are in headset mode. The headset LED is dark (unlit) if you are in handset mode.

Activate/deactivate Group listening controls

The Group listening feature allows you to listen to a call through the speaker, allowing additional parties to listen to both sides of the conversation.

To activate Group listening controls:



Group listening

Select



On



To use Group listening:



To deactivate Group listening controls:



Group listening

Select



Off



1. While on a call, press the **Options** Key.
2. Use the **Navigation** Keys to scroll through the menu and select Group listening.
3. Press the **Select** Key.
4. Press the **On** Key to turn on Group listening.

Lift the **handset** and press the **Speaker** Key.

1. Press the **Options** Key.
2. Select **Group listening**.
3. Press the **Select** Key.
4. Press the **Off** Key to turn Group listening off.

Done



To mute a group listening call:



To switch from Group listening to handsfree:

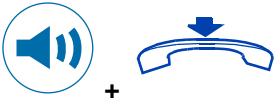

5. Press the **Done** Key to save changes and exit.

1. Press the **Mute** Key. The LED flashes.

2. Press the **Mute** Key again to return to two way conversation.

Hold down the **Speaker** Key while replacing the handset.

Note 1: The Group listening feature must be configured for your telephone by your system administrator. Turn the feature On through the options list to use the feature.

Note 2: You must let the other party know when others are listening to the conversation. This feature does not have a tone to inform the party on the other end of the call that the conversation is being monitored.

Use the Redial list on the M3903

The redial list records the outgoing call numbers.

To access the Redial list on the M3903:



1. Press the **Call Log** Key (M3903).



Redial = Calls out

Select



To use the Redial list:



Dial



2. On the M3903 use the up and down **Navigation** Keys until **Redial = Calls out** appears.
3. Press the **Select** Key.

1. Use the **Navigation** Keys to scroll up and down and highlight the preferred number in the list.
2. Press the **Dial** Key to dial the number.

Note: After pressing the Dial softkey, you will automatically exit the Redial list.

Use the Redial list on the M3904

To access the Redial list on the M3904:

Directory/Log



Redial



To use the Redial list:



Dial



1. Press the **Directory/Log** Key (M3904).
2. Press the **Redial** Key.

1. Use the **Navigation** Keys to scroll up and down and highlight the preferred number in the list.

2. Press the **Dial** Key to dial the number.

Note: After pressing the Dial softkey, you will automatically exit the Redial list.

Use the Predial feature

The Predial feature allows you to enter and preview a number and make corrections before you dial the number.

To use Predial:

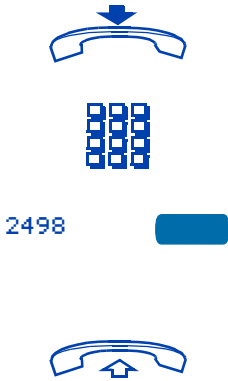

1. Replace the **handset**, if it is off the cradle.
2. **Dial** the number.
3. Press a **Line** (DN) Key to receive dial tone, the displayed predialed number is automatically dialed.
4. Lift the **handset** when the called party answers or, if on handsfree, begin to talk.

To edit a predial number:



1. Without selecting a Line Key, **dial** the number.
2. Use the right and left **Navigation** Keys to move the cursor and edit the number if necessary.
3. When you have made the necessary changes to the number, press a **Line** Key to call the number.

Note: You cannot use the Predial number feature if the Live dial pad feature is active.

Make a call

This section describes features that you can use when you make a call. There are several ways to make a call from your Meridian Digital Telephone. To make a call from your telephone, use the features described in this chapter.

To make a call:

2498



or



or



or

Headset



- Use the **Line** (DN) Key.
- or
- Use the **handset**.
- or
- Use the **Handsfree** Button
- or
- Use the **Headset** Key (M3903 and M3904).

Note: Whenever you read “Lift the handset,” in this guide, you may alternatively press a free Line (DN) Key, Handsfree Button, or the Headset Key. You receive dial tone with each of these actions.

To change from headset to handset:

Headset



The **Headset** Key is used to switch to the headset mode of operation. The LED lights steady to indicate when you are in headset mode.

Make a call while on-hook

To make a call while on-hook, leave the handset in the cradle while you dial a number.

To dial on-hook:

2498



1. Press a **Line** (DN) Key.
2. **Dial** the number when you receive dial tone.
3. Lift the **handset** when the called party answers. If you are on handsfree, begin to talk.

Make a call with the dial pad



1. Lift the **handset**.
2. **Dial** the number.

Auto Dial

Auto Dial lets you dedicate a feature key to a specific telephone number. When pressed, the Auto Dial key dials the number automatically.

To use Auto Dial:



AutoDial



1. Lift the **handset**.
2. Press the associated **Auto Dial** Key. This automatically dials the number.

To display the Auto Dial number:

Display



AutoDial



1. Press the **Display** Key.
- Note:** On the Meridian SL-100, press the Auto Dial Key to displays the number.
2. Press the configured **Auto Dial** Key. The number appears on the display.

To store an Auto Dial number:AutoDial AutoDial 

1. Without lifting the handset, press the appropriate **Auto Dial** Key.
2. **Dial** the telephone number (including access code) to be stored on the selected Auto Dial Key.
3. Press the **Auto Dial** Key a second time. The number is stored on the key you selected.

Note: Use the Change label option to personalize the Auto Dial label.

Activate Ring Again

Use the Ring Again Key when you receive a busy tone or no answer, while you are trying to reach someone in your private network. When you activate Ring Again you receive an audible tone notification when that person is available or has used their telephone. The Ring Again feature allows you to automatically redial the number.

To use Ring Again:RingAgain 

1. **Dial** a number and receive a busy tone or no answer.
2. Press the **Ring Again** Key.
3. Press the **Goodbye** Key.

To call a Ring Again party when you receive notification:



RingAgain



To cancel Ring Again before notification:

RingAgain



When the number you want to reach is available, or the person has re-used their set, you hear the Ring Again tone.

1. Lift the **handset**, you receive dial tone.
2. Press the **Ring Again** Key.

Press the **Ring Again** Key a second time before hearing the audible tone notification.

Note: On the Meridian SL-100, the Ring Again feature is only available for busy tone.

Redial last number called

Last Number Redial allows you to automatically redial the last number you dialed.

To use last Number Redial:

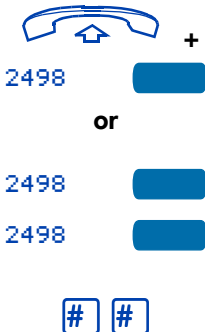

Lift the **handset** and press the **Line** Key.

or

Press the **Line** (DN) Key twice, the last number you dialed is automatically re-dialed.

Note: On the Meridian SL-100, press the Octothorpe Key twice.

Note: Your system administrator must configure this feature for your telephone.

Use Speed Call

Speed Call allows you to automatically dial frequently called telephone numbers by entering a one, two, or three digit code. See your system administrator to determine the capacity of your Speed Call list. A telephone designated as a Speed Call Controller can program or edit the Speed Call list.

To store or change a Speed Call number:

SpcCtrlr



SpcCtrlr



1. Press the **Speed Call** Key. The triangular icon flashes, indicating programming mode.
2. The phone prompts you to **dial** a one, two, or three digit code and telephone number.

Note: Dial the access code (if required), internal, external, or long-distance telephone number.

3. Press the **Speed Call** Key again to save the code and number.

The flashing icon turns off.

To delete a Speed Call number:

SpcCtrlr



Delete



1. Press the **Speed Call** Key.
2. **Dial** the Speed Call code that you want to delete.
3. Press the **Delete** Key.

To make a Speed Call:



SpcCtrlr



1. Lift the **handset**.
2. Press the **Speed Call** Key.



3. **Dial** the Speed Call code.

Make a System Speed Call

System Speed Call allows you to dial Speed Call codes and override all restrictions while on the call. The System Speed Call feature is set up by your system administrator on the system. It is a speed dial number that is common to many users, therefore it is set up on the system not your desktop telephone.

To make a System Speed Call:



SPcCt.Lr



or



1. Lift the **handset**.
2. Press the **Speed Call** Key.
3. **Dial** the Speed Call code of the number you want to dial.

or

Press the special **Auto Dial** Key assigned by your system administrator for that speed call number (example, Message Key).

The number is automatically dialed.

Use Hot Line

The system administrator can program a Hot Line Key that allows you to dial a specific number automatically. The system administrator can apply other features to the Hot Line such as Call Redirection, so that the Hot Line call is answered by a person not a mail box.

To use Hot Line:

Hot Line



Press the **Hot Line** Key. The Hot Line Key automatically dials the number.

Note 1: On the Meridian SL-100 system, the Automatic Line (AUL) feature is the same as the Hot Line feature.

Note 2: If your main Line (DN) is a Hot Line, lift the handset. The Hot Line dials the number automatically.

Make an Intercom call

The Intercom feature connects a group of people together through an Intercom Key. You can use the Intercom feature to call a member of your intercom group by pressing a code assigned to each member of the group. The intercom group must be set up by your system administrator.

To make an Intercom call:



InterCom



1. Lift the **handset**.
2. Press the **Intercom** Key.
3. **Dial** the one or two digit code for the intercom group member you wish to call.

To answer an Intercom call while on a line other than your Intercom group line:



or



1. Press the **Hold** Key to put the current call on hold.
- or
- Press the **Goodbye** Key to end the call.

InterCom



2. Press the **Intercom** Key and begin to speak.

Answer a call

When you receive an incoming call, your telephone rings and the LCD indicator flashes.

To answer a call:



or



or

2498



or



Lift the **handset**.

or

Press the **Handfree** Button located on the left side of the handset (M3902, M3903, and M3904).

or

Press the **Line** (DN) Key beside the LCD indicator as it flashes.

or

Press the **Headset** Key when using a headset.

While on an active call

This section describes features that you can use while on an active call.

Place a call on Hold

Use the Hold feature when you are on the line with one party and a second call comes in on a second line. You can answer the second call and retain the original call by putting it on Hold.

To place a call on Hold:



Press the **Hold** Key. The LCD indicator flashes beside the line on hold.

Note 1: If Automatic Hold is on, the active call is automatically put on Hold when you answer the second call. On the Meridian SL-100 Automatic hold is the default.

Note 2: The caller hears music while on hold, if the music feature is on your system.

To retrieve a call on hold:



Press the **Line** (DN) Key beside the flashing LCD indicator.

Transfer a call

The Transfer a call feature is used to redirect a call to the appropriate person.

To use the Transfer feature to direct a call to a third party.

Trans

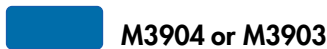

1. Press the **Transfer** Key The other party is on hold and you receive dial tone. The LCD indicator lights steadily.

2. **Dial** the number where you are transferring the call.

While on an active call

Trans



M3904 or M3903

Transfer



M3902

To go back to the original call if the transfer is incomplete:

2498



3. When you hear the ring or a person answers, press the **Transfer** Key again to complete the call transfer.

The LCD indicator goes from steady on to off.

If the person you called is not available: Press the **Line** (DN) Key next to the LCD indicator, to reconnect to the original call.

Note: On the Meridian SL-100, press the Transfer Key, dial the number and press the Goodbye Key. If you press the transfer Key the second time you get a three way conference.

Use Timed Reminder Recall

Timed Reminder Recall gives you a reminder tone when a call you transferred is not answered.

To use Timed Reminder Recall:

Trans



Trans



or



1. Press the **Transfer** Key. The call is put on hold.
2. **Dial** the number where you want to transfer the call.
3. Press the **Transfer** Key again.

or

Replace the **handset** before the extension answers. This starts the recall timer.

Note 1: On the Meridian SL-100, do not press the Transfer Key again; replace the handset before the extension answers. Meridian SL-100 uses the Blind Transfer Recall feature.

Note 2: If the transfer is complete, the recall timer stops.

If the transferred call is not answered, your telephone rings:

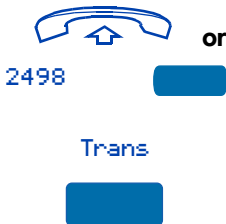

1. Lift the **handset** or press the **Line** (DN) Key, you connect back to the original caller.
2. Press the **Transfer** Key and repeat the transfer (to a different DN).

Note: If you transfer a call to a person and they pick up the line while you are still on the line, press the Goodbye Key to complete the transfer. Check with your system administrator to determine the time interval of your Recall timer.

Use Attendant Recall

The Attendant Recall feature allows you to contact an attendant while on a call and connect the call to the attendant.

To contact the attendant while on a call:

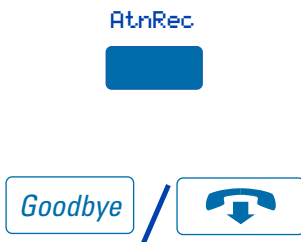

1. Press the **Attendant Recall** Key while on a call.
Stay on the line until the attendant answers.
2. Press the **Goodbye** Key. The caller remains connected to the attendant.

Note: On the Meridian SL-100, the Attendant Recall Key is not available; use the Transfer Key to connect a call to the attendant.

Use Call Park

Call Park allows a call to be held temporarily, to be retrieved from any telephone. You can park an incoming call and page the called party. When you use Call Park you do not tie up a line. Your system administrator can set up a System Park DN where most calls get automatically parked.

If configured network wide, Call Park can be used across networks.

To Park a call on the System Park Extension or your own DN:

Park



While on an active call, press the **Park** Key.

If there is a System Park DN, the call automatically parks on the System Park DN. Otherwise, it parks on your DN.

Note: On the Meridian SL-100, press the Park Key and you receive a confirmation tone. Press the Park again or the Goodbye Key.

To park a call on a DN other than the System Park Extension or your own DN:

Park



Park



1. Press the **Park** Key.
2. **Dial** the DN where you want to park the call.
3. Press the **Park** Key again.

Note: On Meridian SL-100, press Directed Call Park (DCPK) Key. Dial the DN where you want to park the call. Press DCPK again.

To park a call using the SPRE code or FFC/FAC:

Trans or Conf



1. Press the **Transfer** Key or press the **Conference** Key.

SPRE code + **or** Call Park
FFC/FAC



Trans **or** Conf



To retrieve a parked call:



Park **or**



Enter



+

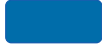

or



2. **Dial** the SPRE code or dial (enter) the Call Park FFC (Meridian 1), or the FAC (Meridian SL-100).

If you do not want the System Park Extension or your own DN, **Dial** a DN where you want to park the call.

3. Press the **Transfer** Key **or** press the **Conference** Key.

Note: On the Meridian SL-100, press the Transfer Key. Do not press the Conference Key.

1. Lift the **handset**.
2. **Dial** the SPRE code or dial (enter) the Call Park FFC (Meridian 1), or the FAC (Meridian SL-100) followed by the **Enter** Key.
3. **Dial** the DN where you parked the call.

Note: If a parked call is not retrieved within a specified period of time, it rings back to your telephone or to the attendant. Check with your system administrator to determine your specified period of time.

Record a Calling Party Number

Calling Party Number allows you to record a caller's number or charge account number for account purposes while on an established call.

To record a caller's number:

Charge



1. While on an active call, press the **Charge** Key.

While on an active call

CParty



Enter



Charge is not allowed

2. Press the **Call Party** Key.
Enter number appears on the display.
3. **Dial** the charge number.
4. Press the **Enter** Key.

Note: If Calling Party Number is invalid the screen displays, Charge is not allowed

To charge a call to a charge account:

Charge



Account



Enter



Exit



While on an active call.

1. Press the **Charge** Key.
2. Press the **Account** Key.
3. **Dial** the charge account number.
4. Press the **Enter** Key.
5. Press the **Exit** Key.

Note: On the Meridian SL-100, flash the switchhook and enter the Account feature code. The code is provided by your system administrator.

Display incoming calls

The Display call information allows you to be on an active call and display a second caller's name without interfering with the current call in progress, if not automatically displayed.

To view the name of a second caller while on a call in progress:

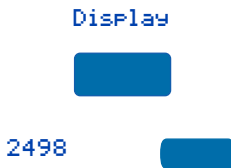

1. Press the **Display** Key.
2. Press the flashing **Line** (DN) Key. The call waiting information appears on the display.

Note 1: To display the second caller's name does not interfere with the current call in progress.

Note 2: You can use the Display Key with other feature keys to display information associated with the feature keys.

Note 3: On the Meridian SL-100, press the Inspect Key to view information on a second caller, while on an active call.

Trace a Malicious call

Malicious Call Trace provides a way for you to trace nuisance calls within your system.

To use Call Trace while you are on a call:



Press the **Call Trace** Key.

Note: On the Meridian SL-100, press the Malicious Call Hold (MCH) Key.

To use Call Trace if you do not have a trace button:



1. Press the **Transfer** Key or the **Conference** Key.

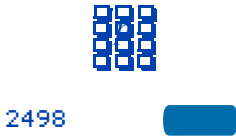

Note: On the Meridian SL-100, press only the Transfer Key.

2. **Dial** the Trace FFC (Meridian 1 system) **or** the FAC (Meridian SL-100 system).
3. Press the **Line** (DN) Key beside the flashing LCD indicator to return to the call.

Incoming calls

This section describes features that you can use with incoming calls.

Activate Automatic Answerback

When Automatic Answerback is active, your set automatically answers in handsfree mode after one ring.

Note: When Automatic Answerback is active, calls do not forward to your voice message service.

To use Automatic Answerback:

AnsBk



On



Exit



1. Press the **Automatic Answerback** Key.
2. Press the **On** Key to toggle Automatic Answerback on.
3. Press the **Exit** Key.

To deactivate Automatic Answerback:

AnsBk



Off



Exit



1. Press the **Automatic Answerback** Key.
2. Press the **Off** Key to toggle Automatic Answerback off.
3. Press the **Exit** Key.

Activate Call Pickup

Call Pickup allows you to pick up a call from any telephone in the same Pickup Group or another Pickup Group.

To answer a call in your own Call Pickup Group:



GrpPkup



1. Lift the **handset**.
2. Press the **Group Pickup** Key.

To answer an incoming call in another Call Pickup group:



GrpPicup



1. Lift the **handset**.
2. Press the **Group Pickup** Key.
3. **Dial** the pickup group number of the telephone that rings.

Note 1: If the Group DN is invalid, you receive an overflow burst tone and the screen displays "**Goodbye try again**". Press the Goodbye Key.

Note 2: The system administrator assigns the group pickup code.

Note 3: To answer an incoming call in another call pickup group is not available on the Meridian SL-100 system.

To answer a call at a specific extension in any pickup group:



1. Lift the **handset**.

Pickup



2. Press the **Pickup** Key.
3. **Dial** the DN of the telephone that you hear ringing (in your call pickup group).

Note 1: Meridian SL-100 uses Directed Call Pickup, with a feature activation code (FAC) access.

Note 2: If the pickup DN is invalid, you receive an overflow burst tone and the screen displays "Goodbye try again." Press the Goodbye Key.

Use Call Waiting

Call Waiting puts your current call on hold, while you answer the next call.

Example: The attendant routes an outside call to you while you are on an existing call. Call Waiting allows you to recognize the call and respond to it.

To answer an incoming call while on another call:



1. Press the **Hold** Key to put a current call on hold (you receive the incoming call tone).

Note: If the Automatic Hold feature is enabled, it is not necessary to press the Hold Key. The call is automatically put on hold when you answer the second call.

CallWait



2. Press the **Call Waiting** Key to answer the call.

To return to your first telephone call:



or



2498



1. Press the **Hold** Key if you want to put the second call on hold.

or

Press the **Goodbye** Key to end the second call.

2. Press the **Line (DN)** Key associated with the first call.

If you do not have a Call Waiting Key:



2498



1. If you do not have a Call Waiting Key and you hear the Call Waiting tone, press the **Goodbye** Key to end your current call.
2. Press the **Line (DN)** Key beside the flashing status icon to answer the incoming call.

While you are away from your desk

This section describes features that you may wish to use when you are away from your desk.

Call Forward

Call Forward allows you to direct your calls to ring at another Line (DN). If the telephone begins to ring, you cannot forward an incoming call in progress.

To forward your calls or change the forward number:

Forward



Forward



To cancel Call Forward:

Forward



To reinstate Call Forward to the same number:

Forward Forward



1. Press the **Forward** Key.
2. **Dial** the DN where you want to forward your calls.
3. Press the **Forward** Key.

Press the **Forward** Key.

Press the **Forward** Key Twice.

Call Forward - Internal

Call Forward—Internal allows only calls originating at internal DNs to ring at another DN. Calls originating outside your Meridian 1 system will still ring at your telephone. You cannot forward calls while your telephone is ringing.

To forward your internal calls:

IntCFwd



1. Press **Internal Call Forward**.



IntCFwd



2. **Dial** the DN where you want to forward your calls.
3. Press the **Internal Call Forward** Key.

To cancel Internal Call Forward:

IntCFwd



Press the **Internal Call Forward** Key.

To reinstate Call Forward to the same number:

IntCFwd



IntCFwd



Press the **Internal Call Forward** Key twice.

Note: The Meridian SL-100 uses Call Forward Busy/Don't Answer Internal/External Feature. This feature allows Meridian SL-100 users to:

- Forward an incoming call which originated internally from a DN in the same customer group as you
- Forward an incoming call which originated externally from a DN out of your customer group to a DN outside your customer group.

You can activate this feature by using a FAC (feature access code 4).

Use Remote Call Forward

Remote Call Forward allows you (from any telephone other than your own) to forward your calls to any telephone.

Note: On the Meridian SL-100, dial the Remote Access Directory Number. You are prompted to enter the directory number of your telephone and dial the Call Forwarding Remote Activation Code. This allows you to activate, deactivate, or change call forwarding to a new destination.

To activate Remote Call Forward:



To cancel Remote Call Forward:



1. Lift the **handset**.
2. If you call from a telephone outside the system, first **dial** your direct system access number and wait for dial tone.
3. **Dial** the Remote Call Forward FFC to activate the feature.
4. **Dial** your Electronic Lock password.
Note: Refer to "Secure your telephone" on page 40.
5. **Dial** your DN.
You get a dial tone before you dial your number.
6. **Dial** the number where you want to forward your calls. If you forward calls to an invalid number, you receive a fast busy.
7. Press the **Octothorpe** Key.
To forward calls to a previous call forward telephone number, skip step six above.

1. Lift the **handset**.
2. If you call from a telephone outside the system, **dial** the Direct system access number and wait for the dial tone.
3. **Dial** the FFC deactivate key code for Remote Call Forward.

While you are away from your desk



4. **Dial** your Electronic Lock password.
5. **Dial** your DN.
You get a dial tone before you dial your number.
6. Press the **Octothorpe** Key.

Secure your telephone

You can lock your telephone with a password so that no one can make calls from your office. The lock consists of a password which you may change.

To lock your telephone:



1. Lift the **handset**.
2. **Dial** the electronic Lock FFC.
3. **Dial** your electronic lock password.
4. If you perform this operation from a different telephone, **Dial** your DN, otherwise go to step five.
5. Press the **Goodbye** Key.

To unlock your telephone:



1. Lift the **handset**.
2. **Dial** the Unlock FFC.
3. **Dial** your electronic lock password.



4. If you are on a telephone other than your own, **dial** your DN.
5. Press the **Goodbye** Key.

To change your electronic lock password:



1. Lift the **handset**.
2. **Dial** the electronic lock password Change FFC.
3. **Dial** the current password for your telephone.
4. **Dial** the new password.
5. **Dial** the new password again.

Note 1: This feature is not available on the Meridian SL-100.

Note 2: You cannot change your password from a remote set.

Talk with more than one person

This chapter describes features which allow you to talk with more than one person at the same time.

Join a call

To connect a call to your current call:

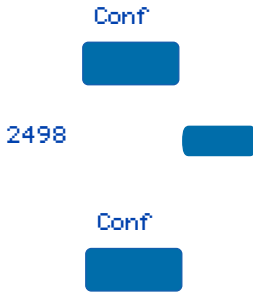

1. While on a call, press the **Conference** Key.
2. Press the flashing **Line** (DN) Key that has the new call.
3. Press the **Conference** Key again.

The person on hold joins your conversation.

Set up a Conference call

You can set up a conference call for three (or six) people, this includes yourself. Contact your system administrator to find out the maximum number of people you can join in a conference on your system.

To set up a conference call:



1. While on a call, press the **Conference** Key. The other party is on hold and you receive dial tone.
2. **Dial** the number of the person you want to add to the conference call. You can talk privately to the person you are adding at this time.
3. Press the **Conference** Key a second time to conference all parties together.

Note: If necessary, repeat the procedure to include up to six people in the conference.

If the person you added to the conference is unavailable:



2498



1. Press the **Goodbye** Key.
2. Press the **Line** (DN) Key with the flashing icon to return to your original call.

Selectable Conferee display and Disconnect

You can view the list of active conferees by using the Conferee Selectable Display Key and disconnect any party that has been added to the conference call. This feature is not available on the Meridian SL-100 system.

To view active conferees:

Conf Display 

1. While on a conference call, press the **Conferee Selectable Display** Key. The LCD indicator turns on. With each key press, the screen changes to show a different active conferee.

Note: This action has no effect on the displays of the other telephones involved in the conference.



2. Press the **Goodbye** Key. If configured, the Conference Count Display returns. The LCD indicator turns off.

To disconnect a conferee:

Conf Display 

1. While on a conference call, press the **Conferee Selectable Display** Key. The LCD indicator turns on. Continue to press the key until the conferee you want to delete appears on the screen.

2498



2. Press the **DN** Key on which the conference call is established. The selected conferee is disconnected from the call.

Note: If there are additional conferees to be disconnected, press the **Conferee Selectable Display** Key until the conferee that is to be disconnected is displayed on the screen.



3. Press the **Goodbye** Key. If configured the Conference Count Display returns and is updated to reflect the revised total count of conferees. The LCD indicator turns off.

Use Group Call

Group Call automatically calls members of a predefined group, one at a time, until they all answer. Ask your system administrator for details on how to create a conference call group.

Note: On the Meridian SL-100, use the Preset conference feature for group calls. Dial the specific DN for Preset Conference, simultaneous ringing of the pre-selected parties is activated.

To call group members:



1. Lift the **handset**.
2. Press the **Group Call** Key. The feature automatically calls all group members. The icon flashes until all members answer.

Their phone numbers appear on the display as they answer. When the last person answers, the **Group Call** indicator lights steadily.

Note: After all the people in the group have answered, only the person who made the group call can put the call on hold.

To answer a Group Call:



Press the **Group Call** Key or multi-appearance DN Key.

Note 1: If you are on a call and you receive three short tones, this is the notification of a group call on your Line (DN).

Note 2: If you are on a call on another telephone in your group, you receive a long tone through the handset or speaker.

Note 3: You do not get a notification of a group call if you are already on a conference or group call.

To end a Group Call:



Press the **Goodbye** Key.

Note: When the person who made the group call disconnects, the call terminates for all members of the group. However, the members of the Group Call can disconnect from the call and not affect other members on the call.

Work without interruption

This chapter describes features that provide you with uninterrupted work time.

Activate Make Set Busy

Make Set Busy allows you to make your telephone appear busy to all callers.

To activate **Make Set Busy**:

MkBusy



Press the **Make Set Busy** Key.

To deactivate **Make Set Busy**:

MkBusy



Press the **Make Set Busy** Key a second time to deactivate the feature.

Additional Call Features

Auto Dial Transfer Feature

Auto Dial Transfer allows you to use your Auto Dial Key to transmit digits to the central office after a Trunk Switchhook Flash. You must be on a central office/exchange (CO) trunk call from or to a CO which offers Centrex or exchange line-type features.

To use Auto Dial Transfer when you pick up an incoming trunk call:

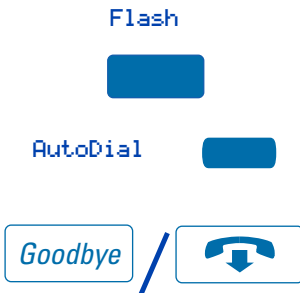

1. Press the **Trunk Switchhook Flash** Key and wait for interrupted dial tone. You receive a speed dial tone.
2. Press the **Auto Dial** Key to call the number desired.
3. Press the **Goodbye** Key to end the call.

Note: On the Meridian SL-100, Auto Dial can be used to transfer calls however, you do not have to be on a central office trunk call, and the Trunk Switchhook Flash key is not applicable to the Meridian SL-100.

Use the buzz signal

Two telephones can link together to allow one person to signal the other. The person signaled hears a buzz. Use this feature to notify the other person of a call, a visitor, or a request.

To buzz the telephone linked to yours:



1. Press the **Buzz** Key.
The telephone linked to yours, buzzes as long as you hold down the key.
2. When you are finished, release the **Buzz** Key.

Note: Buzz signal is not available on the Meridian SL-100.

Call Page (Connect) to make an announcement

To connect to the Call Page allows you to make an announcement over the page system. To make a page call, dial the page trunk access code.

Note: When the Page Key is used on an attendant console it overrides the telephones; the telephones disconnect and must re-access the page trunk.

To connect to the Call Page:



1. Lift the **handset**.
2. **Dial** the page trunk access code.
The connection to the page system is complete.
3. Make your announcement.

To disconnect the Call Page:



Press the **Goodbye** Key.

Centrex/Exchange Switchhook Flash

Centrex/Exchange Switchhook Flash allows you to signal the Central Office/Exchange (CO) during an established call to use a Centrex service such as call transfer or three-way calling.

To use Centrex/Exchange Line Switchhook Flash:

Flash



1. Press the **Trunk Switchhook Flash** Key
You receive special dial tone.
2. **Dial** the codes for your custom Centrex feature.
3. Press the **Goodbye** Key to end the call.

Note: The Meridian SL-100 is a central office based PBX, and this feature is not available.

Charge a call or Charge a Forced call

Call Charge allows you to charge a call to a specific account. Forced Charge allows you to charge long-distance calls from a telephone restricted to local calls.

Note: On the Meridian SL-100, the Account code allows a user to enter a billing number. If the account code is required, the user is prompted to enter a code by a tone after the telephone number is dialed. If a user wishes to voluntarily enter an account code, then flash the switchhook and enter the feature code, which is provided by your system administrator.

To charge a local or long-distance call to an account before you dial:

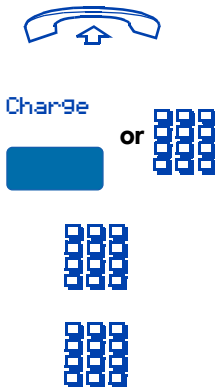

1. Lift the **handset**.
2. Press the **Charge** Key or **dial** an FFC.
3. **Dial** the charge account number.
4. When you receive dial tone, **dial** the number.

To charge a call in progress:

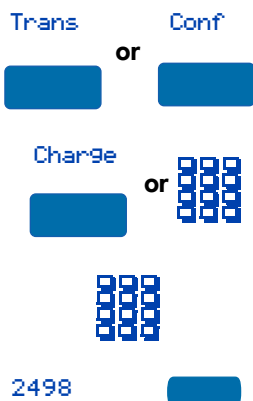

1. Press the **Transfer** Key or the **Conference** Key.
2. Press the **Charge** Key or **dial** the FFC.
3. **Dial** the charge account number.
4. Press the **Line** (DN) Key to return to your call.

To charge a call to an account when you transfer a call:

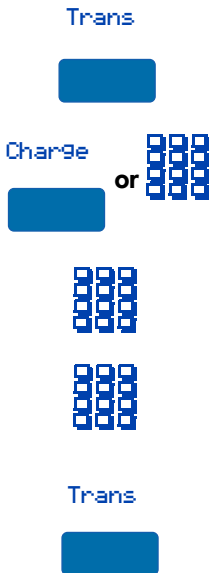

1. Press the **Transfer** Key. The call is on hold.
2. Press the **Charge** Key **or dial** the FFC.
3. **Dial** the charge account number.
4. After you receive dial tone **dial** the number to where the call is to be transferred.
5. Press the **Transfer** Key when you hear the telephone ring.

Note: You can talk privately to the person at the transfer number before you press the Transfer Key.

To charge a call to an account when you add someone to a conference call:

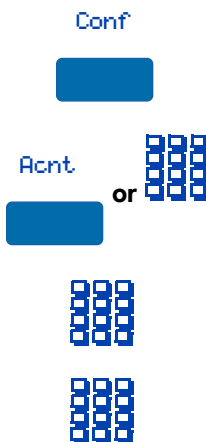

1. Press the **Conference** Key. The call is on hold.
2. Press the **Account** Key **or dial** the FFC.
3. **Dial** the charge account number.
4. **Dial** the number of the person you want to add to the conference.

Conf



5. Press the **Conference** Key.

Enhanced Override Feature

Enhanced Override allows you to override an active call after you have attempted a Forced Camp-on. Use Enhanced Override when you make either a simple call or a consultation call (i.e., place a call on hold and call another party).

To use Enhanced Override:



Override



Conf



1. **Dial** a telephone number and receive a busy signal.
2. Press the **Override** Key.
3. Press the **Conference** Key.

The people on the call in progress receive a tone for approximately one second; the feature connects the three of you together. A short tone repeats.

To end the connection:



Press the **Goodbye** Key.

Note: Activate Enhanced Override is not available on the Meridian SL-100.

Forced Camp-on feature

Forced Camp-on allows your telephone to automatically ring another telephone as soon as that telephone disconnects from its current call. Forced Camp-on allows you to camp on both internal and external calls. Forced Camp-on can be used as a feature by itself or in conjunction with Priority Override. The combination of the two features is referred to as Enhanced Override.

To use **Forced Camp-on**:



1. **Dial** a telephone number and you receive a busy signal.

Override



2. Press the **Override** Key to initiate a Forced Camp-on.

Note: You hear a ringback/ring tone or busy/engaged signal depending on the options chosen. You are now Forced Camped-on to the number you dialed.

3. When the person you called finishes their call, your telephone automatically dials the number.

To answer a camped-on call:



1. Press the **Goodbye** Key.

2. When the telephone rings, lift the **handset**. You are connected to the camped-on call.

Note: Your telephone can be programmed for either Camp-on or Call Waiting, but not both.

Note: Forced Camp-on is not available on Meridian SL-100.

On Hold on Loudspeaker

The On Hold on Loudspeaker feature allows users such as commodities brokers to monitor one (with the optional Loudspeaker) or several (with the Speech Monitor) stock markets, for example, while talking to one or more customers using the handset. At any time, the user can enter the call being monitored on the Loudspeaker or Speech Monitor unit. This feature requires additional equipment.

To use On Hold On Loudspeaker:



LdSpeaker



1. Place the call on **Hold**.

2. Press the **Loudspeaker** Key.

2498



To talk privately to the party on the Loudspeaker:

3. Press the **DN** Key associated with the call on hold. The call on hold is put on the Loudspeaker and is heard publicly.

Use the handset on the Loudspeaker (if provided).

Note: While the Loudspeaker is active, any other call is maintained on the handset. More than one call can be put on hold, but only one call at a time can be placed on the Loudspeaker.

To use On Hold On Loudspeaker:

HotLine



1. Make a call from **Hot Line** or the **DN** of the Speech Monitor.
2. Place the call on **Hold**. The Speech Monitor is automatically activated.

To talk privately to one of the parties on the Speech Monitor

Take the call on the handset of the phone.

Note: This conversation is not heard on the Loudspeaker. Any other user with a Speech Monitor DN on their set can enter the call by establishing a Multiple Appearance Conference.

To disconnect a call from the Speech Monitor:



Press the **Goodbye** Key while the call is active.

To disconnect from the Speech Monitor:

Switch off the Speech Monitor.

Note: This feature is not available on the Meridian SL-100.

Override Feature

You can override a busy signal and interrupt another call.

To override a busy/engaged signal:



Override



1. **Dial** a telephone number and receive a busy signal.
2. Press the **Override** Key.

The people on the call in progress receive a tone for approximately one second; the feature connects the three of you together. A short tone repeats.

To end the connection:

Goodbye



Press the **Goodbye** Key.

Privacy Release Feature

Privacy Release allows one or more people who share your DN to join your call.

To use Privacy Release in an established state:

PrivRls



Press the **Private Release** Key while you are on a call. One person can now join the call, if they press the shared number (DN) Key on their telephone (multiple appearance DN feature).

Radio Page Feature

Some telephone systems can have an on-site Radio Page system. This system feature allows you to page a person and stay on the line until they answer. The paged person answers the call when they enter a special Page “Meet - me” code from any telephone. This connects the person paged to the party who paged them.

Note: On the Meridian SL-100, dial the paging number access code. A network connection is established with the paging access trunk. This provides access to loudspeaker paging equipment. Automatic Pre-selection, Automatic Post-selection, and Special Radio page features do not apply to Meridian SL-100.

Access a Radio Pager:**To use Automatic Pre-selection
("Meet - me" page):**

To contact someone, you can **dial** their Directory Number (DN) or alert them directly through their radio page device.

1. Lift the **handset**.
2. **Dial** the Radio Page FFC. You receive page dial tone.
3. **Dial** the number of the party you want to page. After dialing, you receive a ringback tone.

Note 1: The person you paged uses any telephone to enter a Radio Page Answer code, plus their own DN number. This action connects you and the person paged.

Note 2: If your call goes unanswered for a preset time period, you receive a continuous high pitched tone then silence. Press the Goodbye Key.

To use Automatic Post selection:

RadioPage



The called party is either busy on the telephone or away from the desk.

To page the called party there is no need to redial the number of the called party.

1. Press the **Radio Page** Key. You receive a special dial tone.
2. **Dial** the Radio Page Access FFC. You receive dial tone.

Note 1: The person you have paged can proceed to any telephone, enter their Radio Page Answer code plus their own DN number. This action connects you and the person paged.

Note 2: You receive a fifteen second, high pitched tone, then silence if the party paged does not answer the call within a preset time period. When you receive this signal, replace the handset or press the Goodbye Key.

To use the Special Radio Page feature:



If you carry a Radio Pager, you receive a page indication when someone dials your Directory Number (DN).

If the Radio Page system is set up to function in "Meet - me" mode, you can answer the page call from any telephone. You can connect to the person who paged you.

1. Lift the **handset**.
2. **Dial** the Radio Page Answer FFC. You receive page tone.
3. **Dial** your own DN. You connect to the page caller. You receive a steady high-pitched tone, letting you know the caller has hung up.

Voice Call Feature

You page another person or make an announcement through someone else's telephone speaker.

To make a voice call:



1. Lift the **handset**.

VoiceCall



To respond to a voice call:



or

VoiceCall



2. Press the **Voice Call** Key.
3. Make your announcement.
4. Press the **Goodbye** Key.

Your telephone rings once and you hear the caller's voice through your speaker. Lift the **handset**.

or

Press the **Voice Call** Key and begin to speak.

Note: On the Meridian SL-100 use the Individual Page from the Group Intercom (GIC) feature. Press the GIC Key and dial the appropriate GIC number. After the first ring, press the GIC Key and a one-way connection is established. Make your announcement over the speaker.

Hospitality features

These hospitality features are intended for hotel operations use.

Note: The Hospitality Features are not available on the Meridian SL-100, except for Wake-up Service.

Automatic Wake-Up

Although normally used as a hotel feature, Automatic Wake-up may be useful to business users who require a timed reminder call feature. From your telephone you may program the Meridian 1 system to automatically place a call to you at a predetermined time. When you answer the call, you hear recorded music for up to thirty seconds followed by a pre-recorded announcement, or the attendant.

To enter the time for a wake-up call:



1. Lift the **handset**.
2. **Dial** the Wake-Up Request FFC on the Meridian 1 **or** FAC on the Meridian SL-100.
3. **Dial** the wake-up time in a 24-hour format (hh mm).
4. Press the **Goodbye** Key.

Note: On the Meridian SL-100, after you enter the FAC, you receive a second dial tone. Enter four consecutive digits to specify an hour and minute. The reminder time is specified in military time and is based on a 24 hour format. i.e. 6:00 a.m., input 0600. You receive a confirmation tone.

To cancel a wake-up call:



1. Lift the **handset**.
2. **Dial** the Wake-Up Cancel FFC on the Meridian 1 **or** FAC on the Meridian SL-100.



To verify the time for the wake-up call:



3. Press the **Goodbye** Key.

Note: On the Meridian SL-100, after you enter the FAC, you receive a confirmation tone.

1. Lift the **handset**.

2. **Dial** the Wake-Up Verify FFC.

3. **Dial** the wake-up time in a 24 hour time format (hh mm). If it is correct, you receive a confirmation tone.

Note: This feature is not available on the Meridian SL-100. To change the specified time for a wake-up call on the Meridian SL-100, you must first deactivate the feature and then activate the feature with a new request.



4. Press the **Goodbye** Key.

Note: In 24-hour time format, 7:30 AM is entered as 0730; 9:45 PM is 2145.

Message Registration

If your telephone is equipped with a display, you can read, change, or reset meters that log your hotel telephone calls.

To read meters:

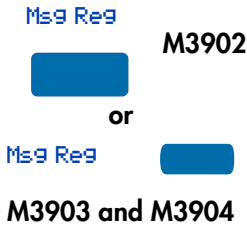

1. Press the **Message Registration** Key.

Note: The Message Registration Key is assigned to one of the three Programmable Feature Keys on the M3902. The message Registration Key is assigned to one of the Programmable Line/Feature Keys on the M3903 and M3904.



Msg Reg

M3902



or

Msg Reg



M3903 and M3904

To change a meter:

Msg Reg

M3902



or

Msg Reg



M3903 and M3904



Msg Reg

M3902



or

Msg Reg



M3903 and M3904

2. **Dial** the room Directory Number (DN).

3. Press the **Message Registration** Key.

1. Press the **Message Registration** Key.

2. **Dial** the room Directory Number (DN).

3. **Dial** the correct meter count.

4. Press the **Asterisk** Key.

5. Press the **Message Registration** Key

To reset a meter to zero:

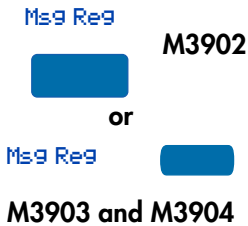
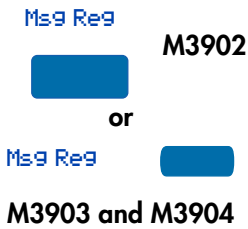

1. Press the **Message Registration** Key.
2. **Dial** the room DN number.
3. Press the **Asterisk** Key.
4. Press the **Message Registration** Key.

Note: The Message Registration Key can be a Fixed Key, Programmable Line/Feature Key, or Programmable Feature Key, depending on the model of the M3900 telephone you are using.

Maid Identification

Maid ID makes it easier to keep track of which maids clean which rooms. The maid enters the information from the telephone in each room.

To enter cleaning status:



1. Lift the **handset**.
2. **Dial** the FFC.



3. **Dial** one of the following cleaning status codes:

- 1 = cleaning requested
- 2 = cleaning in progress
- 3 = room cleaned
- 4 = room passed inspection
- 5 = room failed inspection
- 6 = cleaning skipped
- 7 = not for sale

You receive interrupted dial tone.



4. Press the **Asterisk** Key.
5. **Dial** the Maid ID. If you dial the wrong Maid ID, press the **Octothorpe** Key and redial the ID.



6. Press the **Octothorpe** Key.
7. Press the **Goodbye** Key.



Room Status

Room Status lets you read the status of a room using the Display Module.

To read the status of a room:

RmStatus



1. Press the **Status** Key.



2. **Dial** the Directory Number (DN) for the room. The DN is displayed followed by a two digit code.

The first digit indicates the occupancy status:

0 = room vacant

1 = room occupied

The next digit indicates the cleaning status of the room:

1 = cleaning requested

2 = cleaning in progress

3 = room cleaned

4 = room passed inspection

5 = room failed inspection

6 = cleaning skipped

7 = not for sale

RmStatus



To change the status of a room:

RmStatus



3. Press the **Status** Key.

1. Press the **Status** Key.

2. **Dial** the Directory Number (DN) for the room. The DN is displayed followed by a two digit code.

The first digit indicates the occupancy status:

0 = room vacant

1 = room occupied

The next digit indicates the cleaning status of the room:

- 1 = cleaning requested
- 2 = cleaning in progress
- 3 = room cleaned
- 4 = room passed inspection
- 5 = room failed inspection
- 6 = cleaning skipped
- 7 = not for sale



RmStatus



3. **Dial** the status code you want to assign to the room. A three digit code appears. The first digit indicates the occupancy status. The second digit is the old cleaning status, and the third is the new cleaning status you just entered.
4. Press the **Status** Key.

Note: The Status Key can be a Fixed Key, Programmable Line/Feature Key, or Programmable Feature Key, depending on the model of the M3900 telephone you are using.

Telephone display (M3902, M3903, and M3904)

This section summarizes the display features of the M3902, M3903, and the M3904. Idle display is shown on the figures below.

M3902 display area

The M3902 has one display area for call status and feature information.

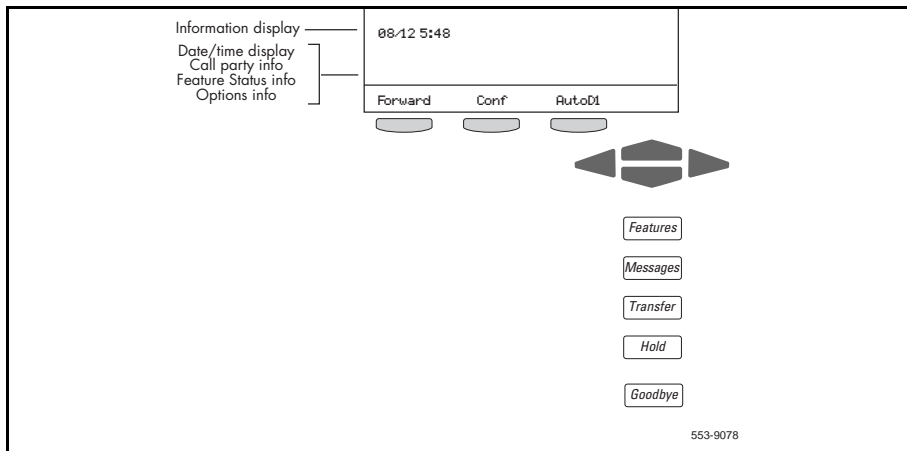

M3903 display area

The M3903 information display shows one item at a time. You must use the Navigation Keys to scroll through the list. When the item you want appears, press the Select Key.

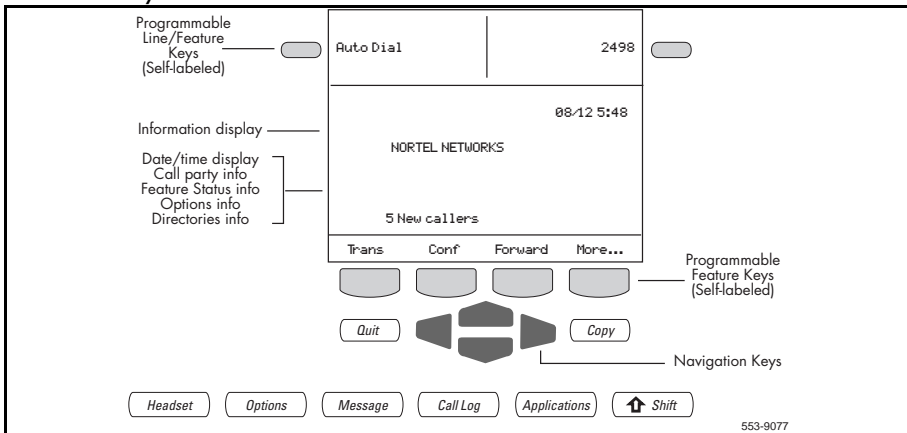

M3904 display area

The M3904 has two display areas. The upper portion of the display area is for call status information, the lower display area is a three line feature information display.

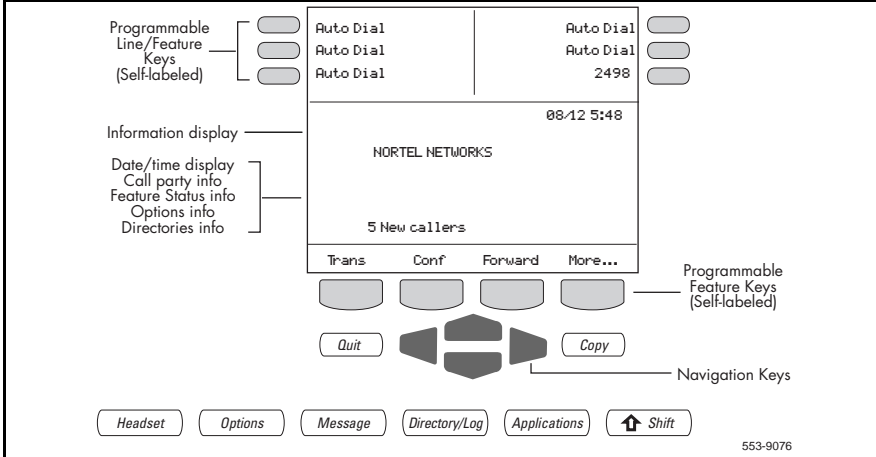

Note: Refer to “Your Telephone’s Controls” on page 5 and “Terms you should know” on page 9 for more information on display and specialized key information.

Use your Options Key (M3902, M3903, M3904)

The display provides information on how to change the various options on your telephone. Most of the features below are available to you on the M3902, M3903, and M3904. Some of the feature are available only if turned on by your system administrator; others are designed for specific M3900 models.

Options feature list

Language...	Date/time format...
Change feature key label	Key click *
Screen contrast...	Headset port on call **
Volume adjustment...	Headset port ext alerter
Ring type...	Call indication light
Call log options *	On-hook default path *
Live dial pad ***	Display diagnostics
Preferred name match ***	Group listening
Area code setup	MCA Controls...
Call timer	

**M3904 only

* M3903 and M3904 only.

Note: The Meridian Communication Adapter (MCA) is unavailable on the Meridian SL-100.

Note: The three dots... appearing after an option item indicates there is a sublist.

Select options

The Options Key lets you customize certain characteristics of your phone. Screen prompts take you step by step through procedures and keep you informed on the status of the adjustable features. Because the display area is smaller on the M3902 and M3903 the first two steps used to access an Option menu item are different from the M3904.

Note: If you press the Quit Key before the Done Key you exit the Options without saving changes. If you press the Done Key to exit you save the changes.



Select



Done



or

Quit



1. Press the **Options** Key to make adjustment to your M3902 and M3903 telephone.
2. Use the **Navigation** Keys to move up and down through the list.
3. Press the **Select** Key when your selection is displayed. The display provides you with information to adjust your selection.
4. Press the **Done** Key to save the changes.

or

Press the **Quit** Key to exit.

To make adjustment to your M3904:



Select



Done



or

Quit



1. Press the **Options** Key and scroll through the list of features that are adjustable for your telephone model.
2. Use the **Navigation** Keys to move up and down through the list. Highlight the feature you would like to adjust.
3. Press the **Select** Key. The display provides you with information to adjust your selection.
4. Press the **Done** Key to save the changes.

or

Press the **Quit** Key to exit.

Select a language

The telephone display is available in multiple languages. After you select Language Selection:



French

Select



Done



or

Quit

1. Use the down **Navigation** Key to select the desired language (e.g., French).
2. Press the **Select** Key.
3. Press the **Done** Key **or** press the **Quit** Key to exit.

Change a feature key label

You can change the name on the Programmable Line/Feature Keys (Self-labeled) by selecting Change key label in your Options list. These keys are located at the sides of the top portion of the display area. Use the Select Key to choose the Change key label option.

To change a feature key label:

Change feature key label

Select



Change feature key label

Restore all key labels

Restore one key label

1. Select the **Change feature key label** from the option menu.
2. Press the **Select** Key.

Select your option from the three items on the subset list.

- Change Feature key label
- Restore all key labels
- Restore one key label

3. The prompt asks you to select the key you want to change.

Note: Press the Programmable Line/Feature Key (Self-labeled) that you

want to change the key label on, for example: change the AutoDial label to Purchasing.

Note: On the M3902 use the Navigation Keys to scroll to the key you want to change the label on. Press the select Key when the Key label appears on the display.



Done



To restore all key labels:

Restore all key labels

Select



Yes

No

or



4. To change a letter press the **Dial pad** Key with that alpha letter. Press the key until the correct alpha letter or number appears. Use the Case Key to change the case of the letter.
5. Use the **Navigation** Keys to move the cursor as you enter the alpha letter or number you need.

Note 1: Continue until you have changed the entire feature label.

Note 2: To select **L** you press the dial pad number **5** three times (555). **L** is the third letter associated with key **5**.

6. Press the **Done** Key to save changes and exit.

1. Select **Restore all key labels**.
2. Press the **Select** Key.
3. Press the **Yes** or the **No** Key.

Note: If you select Yes all original labels are restored. If you select No, you go back to the subset list.

To restore one key label:

Restore one key label

Select



Purchasing



Done



1. Press the **Select** Key to restore one key label.
2. Press the **key** you wish to restore to the original label (e.g., Purchasing).
3. Press the **Done** Key to save changes and exit.

Note 1: You can press the Shift Key if the label you want to change is on the second layer of the Programmable Line/Feature Key (Self-labeled).

Note 2: You cannot change the label on your Primary Directory Number (DN) Key.

Contrast adjustment

The display contrast gives you a choice of how you view the text on your display. After selecting Contrast adjustment:

To adjust display screen contrast:

Lower



or

Higher



Done



1. Press **Lower** to decrease the display contrast level.
or
Higher to increase the display contrast level.
2. Press the **Done** Key to save the changes and exit.

Volume adjustment

Use the Navigation Keys to select Volume Adjustment: (list of items to adjust appear for your telephone model) Ringer, Buzzer, Speaker, Handset listen, Handsfree listen, Headset listen, Headset talk, Headset sidetone.

Select **Ringer**. Press the **Select** Key to adjust the volume of the ringer on your telephone.

Select **Buzzer**. Press the **Select** Key to adjust the buzzer volume. The buzzer feature links two telephones together for quick notification purposes.

Select **Speaker**. Press the **Select** Key to adjust the speaker volume.

Select **Handset listen**. Press the **Select** Key to adjust volume of what you hear through the handset.

Select **Handsfree listen**. Press the **Select** Key to adjust the handsfree speaker volume (If your telephone has handsfree activated).

Select **Headset listen**. Press the **Select** Key to adjust the volume of speech heard through the headset.

Select **Headset talk**. Press the **Select** Key to adjust how loud you speak through your headset.

Select **Headset sidetone** (M3904 only). Press the **Select** Key to adjust Headset sidetone. Sidetone is the sound the user hears through the headset or handset when they are speaking. Without this feedback the user may perceive the telephone as not working.

Press the **Done** Key to save the changes and exit. Press the **Quit** Key to exit without saving changes.

Example: To adjust the Ringer volume:



Select



Volume adjustment...

1. Press the **Option** Key.
2. Use the up and down **Navigation** Keys to scroll through the Options menu.
3. Press the **Select** Key, when the Volume adjustment selection appears.



Select



Ringer

Higher



or

Lower



Done



4. Use the **Navigation** Keys to scroll through the submenu items.
5. Press the **Select** Key when Ringer appears.
The ringer on your telephone begins to ring. The Higher and Lower Keys appear.
6. Press the **Higher** Key to raise the volume of the ringer **or** press the **Lower** Key to lower the volume of the ringer.
7. Press the Done Key to save changes and exit the program.

Choose Ring type

Ring type gives you the choice of telephone ring types or tones. When a ring type appears in the display you can hear the selection prior to activating the tone for your telephone. After you select Ring type:



Ring type 1

Play



Select



Done



1. Use the **Navigation** Keys to scroll through the subset list of Ring type 1, Ring type 2, Ring type 3.
Note: You can only adjust the volume of the ring for your Primary DN.
2. Press the **Play** Key to sample a ring tone.
3. Press the **Select** Key to activate the desired ring type.
4. Press the **Done** Key to save the changes and exit.

Note: The display list contains only the ring types available for your telephone model.

Set Call log option (M3903 and M3904)

When using Call log you have a choice of recording all incoming calls, only the unanswered incoming calls or not to show the logged calls at all. The Call Log stores up to 100 incoming entries on the M3904 and 10 incoming entries on the M3903. Select the Call Log option and follow these steps:

To set Call log option:

Log all calls

Log unanswered calls

Done



1. When you select **Call log** you get two options, select one of the two:
 - Log all calls
 - Log unanswered calls
2. Press the **Done** Key to save the changes and exit.

Use Preferred name match (M3904)

This feature when activated, displays the names of incoming and outgoing callers as stored in your Personal Directory, if the telephone number matches the one stored in your directory. This feature allows you to personalize the displayed names for incoming and outgoing calls. After you select Preferred name match:

On



or

Off



Done



1. Press the **On** Key to turn on Preferred name match.
or
Press the **Off** Key to turn off Preferred name match.
2. Press the **Done** Key to save the changes and exit.

Use Live dial pad (M3904)

A Live dial pad allows you to press any dial pad key to automatically select dial tone on your primary DN. After you select Live dial pad:

On



or

Off



Done



1. Press the **On** Key to turn on Live dial pad.

or

Press the **Off** Key to turn off Live dial pad.

2. Press the **Done** Key to save the changes and exit.

Area code setup

When you enter an area code using this feature, the callers list and CLID display shows the extensions first with the prefix in parenthesis. This makes it easier to identify local calls and internal calls. You can define up to three area codes. After you select Enter area code option, follow these steps:

To enter area codes:

1st Code:4080000

2nd Code:4150000

3rd Code:6500000

Done



1. Put your cursor in the first line and enter an **area/country code** of your choice.
2. Press the **Done** Key to save the changes and exit.

Set Call timer

Call timer measures how long you are on each call. After you select Call timer:

On



or

Off



Done



1. Press the **On** Key to turn on the Call Timer.

or

Press the **Off** Key to turn off the Call Timer.

2. Press the **Done** Key to save the changes and exit.

Format time and date

There are several time/date display formats available to you. After you select Time/date format:



Select



Done



1. Use the up and down **Navigation** Key to scroll through the numbered formats.
2. When the format you want appears on your display, press the **Select** Key.
3. Press the **Done** Key to save the changes and exit.

Note: There are eight time and date formats. There are four time/date formats in 12 hour time formats and four time/date formats in 24 hour time format.

Set Key click

Key click provides a click sound as you press the telephone keys. Select Key click option and follow these steps:

On



or

Off



Done



1. Press the **On** Key to turn on Key click.

or
Press the **Off** Key to turn off Key click.
2. Press the **Done** Key to save the changes and exit.

Use Headset port on call (M3904)

This feature allows you to connect a third party device such as a light to indicate to others that you are on a call. The third party device connects to the headset port and is activated when the user is on a call. Select the Headset port call option to change the headset port.

Note: This feature is reserved for future qualification with third party equipment.



1. Press the **On** Key to turn on the Headset port on call.

or

Press the **Off** Key to turn off the Headset port on call.

2. Press the **Done** Key to save the changes and exit.

Use Headset External Alerter and Recorder Interface (M3903 and M3904)

When activated, the Headset External Alerter and Recorder Interface option, provides an interface for the installation of a visual or audible alerter and or recorder device. The External Alerter or Recording device plugs into the Headset port located on the underneath side of the telephone. Select Headset External Alerter option and follow these steps:

Note: This feature is reserved for future qualification with third party equipment.



1. Press the **On** Key to turn on Headset port.

or

Press the **Off** Key to turn off the Headset port.

2. Press the **Done** Key to save the changes and exit.

Call indicator light

The Call indicator light control allows you to turn on or off the flashing incoming call indicator light. Select Call Indicator light:



1. Press the **On** Key to turn on the Call Indicator light.

or
Press the **Off** to turn off the Call Indicator light.
2. Press the **Done** Key to save changes and exit.

On-hook default path

The on-hook default path opens the voice path automatically either on Headset or Handsfree. Select the On-hook default path:

Handsfree selected

or

Headset selected

Done



1. Select one of the two choices in the submenu of the On-hook default path.

Handsfree selected.

or
Headset selected.
2. Press the **Done** Key to save the changes and exit.

Display diagnostics

The Display diagnostics is used by the technician to check the status of the display to make sure it is functioning correctly. After you select Display diagnostics:



Display diagnostics

1. Use the up or down **Navigation** Keys to scroll through the menu and view the display diagnostics.

Done



2. Press the **Done** Key to exit.

Activate Group listening

The Group listening feature allows you to talk on the handset to another party, while one or more persons are listening to the conversation on the speaker. To activate, select the Group listening option and follow these steps:

On



or

Off



Done



1. Press the **On** Key to turn on Group listening.

or

Press the **Off** Key to turn off Group listening.

2. Press the **Done** Key to save the changes and exit.

Note 1: This feature does not have a tone to inform the party on the other end of the call that the conversation is being monitored. You must let the other party know when others are listening to the conversation.

Note 2: Your system administrator must configure this feature to enable activation.

Set Meridian Communications Adapter controls

The telephone user or the person who installs your Meridian Communication Adapter needs to set the MCA parameters on your telephone. You set the MCA parameters when you select MCA Controls:

Select



1. Press the **Select** Key to select MCA controls.
2. Use the **Navigation** keys to select your choice.

Done



3. Press the **Done** Key to save the changes and exit.

Note 1: Meridian SL-100 does not support MCA.

Note 2: Your system administrator must configure this feature to enable activation.

Directory display and controls (M3903 and M3904)

M3903 Directory display and controls

The M3903 information display shows one item at a time. Use the Navigation Keys to scroll through the list. When the item you want appears, press the Select Key. The figure below shows the status once you log into the directory. The M3903 has a Call Log and Redial list. It does not have a Personal Directory.

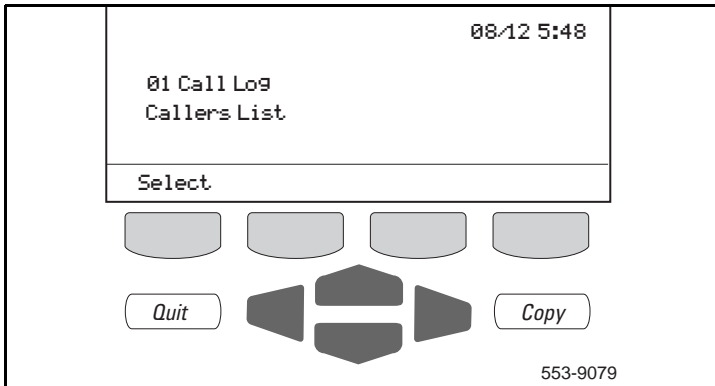

Access your Call Log or Redial List application (M3903)

To access the M3903 Call Log:



Select



1. Press the **Call Log** Key.
2. Press **Select** when the directory you want appears in the display area (M3903).

Call Log

- Call Log

Redial List

- Redial List

Quit

3. To exit the directory press the **Quit** Key.

M3904 Directory display and controls

The information display available on the M3904 model telephone has a three line display. The figure below shows the status once you log into the directory.

Note: Redial and Password are part of the directories menu display. Use the down Navigation Key to view these selections. Press the associated Key under the selections to select the directory you want.

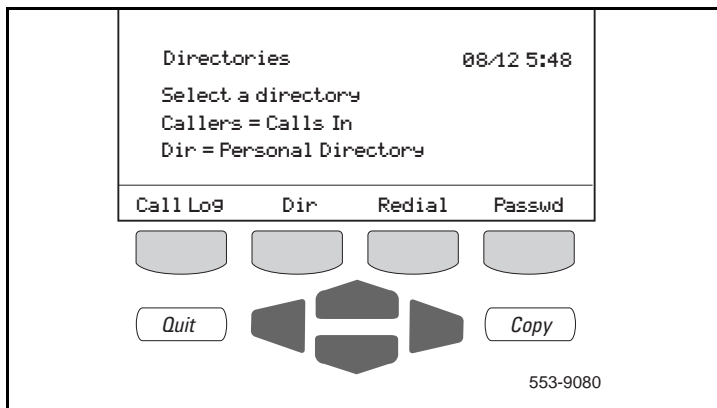

Access your Call Log, Redial or Personal Directory application (M3904)

To access your Call Log, Redial or Personal Directory (M3904) follow these steps:

To access the M3904 directories:

Directory/Log



1. Press the **Directory/Log** Key (M3904).
2. Press one of the following **keys** for the directory you want on the M3904:

CallLog

Dir

Redial

or

or

- Call Log
- Personal Directory
- Redial List (M3904)

Quit

To exit the directory press the **Quit** Key.

Directory password protection (M3904)

You can password protect your Call Log, Redial list and Personal Directory on the M3904 telephone. If password protection is activated, you must enter a password each time you press the Directory/Log Key.

To enable Password protection:

Directory/Log



Passwd



Password enabled: OFF

Select



On



New Password:

1. Press the **Directory/Log** Key.

2. Press the **Password** Key.

3. Press the **Select** Key to choose Password enabled:

4. Press the **On** Key to enable password protection.

The prompt is: New Password.

To define your first password:



Enter



Confirm Password



1. **Dial** the password.

2. Press the **Enter** Key.

The prompt is: Confirm Password.

3. Confirm your password by **dialing** (entering) the password again.

Password enabled: ON

Done



To disable personal directory password:

Directory/Log



Passwd



Off



Done



To change personal directory password:

Directory/Log



Passwd



Select



Define Password

Select



The prompt is:

Password enabled: ON.

4. Press the **Done** Key to save the changes and exit.

1. Press the **Directory/Log** Key.

2. Press the **Password** Key.

3. Press the **Off** Key to disable Password Protection.

4. Press the **Done** Key to save the changes and exit.

1. Press the **Directory/Log** Key.

2. Press the **Password** Key.

3. Press the **Select** Key to choose Define password.

4. Press the **Select** Key to choose New password.

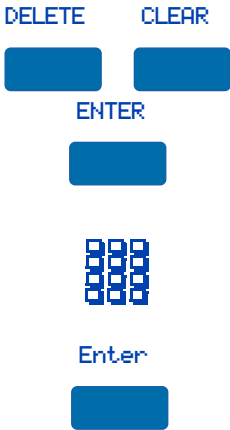

Confirm Password



When you Select New password, three keys appear

DELETE

CLEAR

ENTER

5. **Dial** your new password at the prompt.
6. Press the **Enter** Key.

The prompt is: Confirm Password.

7. **Dial** your new password again.
8. Press the **Enter** Key.
9. Press the **Done** Key to save the changes and exit.

Call Log (M3903 and M3904)

The Call Log feature provides access to the name and number of incoming calls, and can be password protected on the M3904. You can activate Call Log to record all calls, record only the unanswered incoming calls or not record any calls. The incoming calls are stored in order of date and time received. The oldest call is stored at the top of the list. The newest call is stored at the bottom of the list.

The M3904 Call log list stores up to 20 entries for incoming calls and 10 entries of outgoing calls in the Redial List. The M3904 can copy a number from the Caller's Log and store it in the Personal Directory.

The M3903 Call log list holds up to 10 entries for incoming calls and 5 entries of outgoing calls in the Redial List.

Access and use the Call Log (M3903)

To enter the Call Log list:



Press the **Call Log** Key on the M3903.

To use the Call Log:

Old



or

New



Press the **Old** Key to go to the top of the old calls list.

or

Press the **New** Key, to go to the top of the new call list.

To make a call from the Call Log:



408 565 2494

Dial



1. Use the **Navigation** Keys to scroll through the Call Log and select the number you want to call in the Call Log list.
2. Use the **Dial** Key to call the number selected. You leave the Call Log when you make the call.

To exit the Call Log:



Press the **Quit** Key.

Access and use the Call Log (M3904)

To enter the Call Log list:



1. Press the **Directory/Log** Key on the M3904.
2. Press the **Call Log** Key.



To use the Call Log:

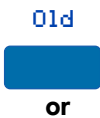

Press the **Old** Key to go to the top of the old calls list.

or



Press the **New** Key, to go to the top of the new call list.

To make a call from the Call Log:



1. Use the **Navigation** Keys to scroll through the Call Log and select the number you want to call in the Call Log list.

408 565 2494



2. Use the **Dial** Key to call the number selected. You leave the Call Log when you make the call.

To exit the Call Log:



Press the **Quit** Key.

Redial List (M3903 and M3904)

The Redial list records your last 10 (M3904) or 5 (M3903) outgoing call numbers and can be password protected on the M3904. On the M3904 you can copy these numbers to your Personal Directory.

Use the Redial List (M3903)

To select a number on your Redial List:



Select



Redial list



Dial



1. Press the **Call Log** Key.
2. Press the **Select** Key when the **Redial list** appears on the display.
3. Use the **Navigation** Keys to select the entry you want.
4. Press the **Dial** Key. Your call is automatically dialed and you exit the Redial List.

Use the Redial List (M3904)

To select a number on your Redial List:



Redial



1. Press the **Directory/Log** Key.
2. Press the **Redial** Key.
3. Use the **Navigation** Keys to select the entry you need.

Dial



4. Press the **Dial** Key. Your call is automatically dialed and you exit the Redial List.

Personal Directory (M3904)

The Personal Directory provides a directory of names and numbers. The Personal Directory allows you to add, delete, search and change an entry. The Personal Directory holds up to 100 entries (an entry is one name and one telephone number). You can add a directory entry by copying the entry from your Call Log or Redial list, add an individual entry with the "Add New" Key or by using the Personal Directory PC Utility Application. The Personal Directory PC Utility is an accessory cartridge that connects your M3904 telephone to your PC. You can create a directory on your PC and transfer it to your M3904 Telephone. You can also copy call party name and number from your display and copy into your Personal Directory.

The Directory Display and Controls (M3904 only)

The figure below shows the status once you log into the directory.

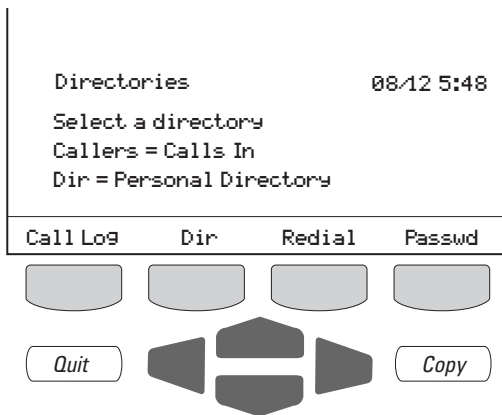

553-9080

To enter the Personal Directory:



1. Press the **Directory/Log** Key.

Dir



Add New



or

DelList



Quit

To search the Personal Directory:



Directory/Log



or

Quit

2. Press the **Directory** Key.

Note: The displays shows the number of entries in the Personal Directory. The **Add New** Key appears if less than 100 entries exist in your Personal Directory.

3. Press the **Add New** Key to add a Personal Directory entry.

or

Press the **Delete List** Key to Delete all list entries in your Personal Directory.

4. Press the **Quit** Key to exit the Personal Directory.

1. Use **Navigation** Key to move through the directory list or use the "first letter of the name" to find a name match.
2. Select a **Directory list** by alphabet listings. (example press **L** for names that begin with **L** (press 5 on the dial pad three times for the letter **L**)).
3. To exit press **Directory/Log** Key.

or

Press the **Quit** Key.

Add a Personal Directory entry

Directory/Log



1. Press the **Directory/Log** Key.

Dir



AddNew



Example: to enter the name **Chris**:

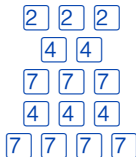

Next



Enter the number.



Done



2. Press the **Personal Directory** Key.
3. Press the **Add New** Key.
4. **Dial** (enter) the new name.

Dial (enter) the name using the key pad.

Press the **dial pad** key with the desired letter repeatedly until that letter appears on the display.

Press the right **arrow** key to go to the next letter.

Note: The cursor automatically advances to the next position if a different key from the last is pressed.

5. Press the **Next** Key to add the telephone number.

1. Use the **dial** pad.
2. Press the **key** with the desired number.
Continue until your number is complete.
3. Press the **Done** Key to save the changes and exit.

The prompt is: **Saved**.

Saved

Save number from incoming call to Personal Directory

While answering an incoming call you can add that call to your Personal Directory, while you are on the call. If you do not add the call at this time you can go into the Call Log later and add the call to the Personal Directory as long as you have selected the Call log to record all incoming calls.

To save the number from an incoming call to the Personal Directory:



Copy to

Edit



or

Save



1. Press the **Copy** Key, while on the call.

The prompt is: COPY to.

2. Press the **Edit** Key, to change the calling party name/number.

or

Press the **Save** Key.

Delete or edit an entry

You can delete an entry in your Personal Directory when you follow these steps.

To edit a Personal Directory entry:



Dir



1. Press the **Directory/Log** Key.

2. Press the **Directory** Key.

3. Use the **Navigation** Keys to scroll to and highlight the desired entry you want to delete or edit.

Note: In addition to using the Navigation Keys to search for a entry, you can use the search feature.

Delete



Yes



Dial



Edit AddNew Delete



Edit



Quit



To delete an entry

Directory/Log



Dir



4. Press the **Delete** Key to delete the currently highlighted entry in your Personal Directory.
5. Press the **Yes** Key to confirm entry deletion.

When you scroll through, a list four Keys appear:

DIAL

EDIT

ADDNEW

DELETE.

6. Press **Edit** Key to change the telephone number or characters in name.
7. Use the **Navigation** Keys to move the cursor to the digit or character you wish to change. Highlight the existing digit or character with the cursor and use the dial pad to write over the entry.
8. When you have completed the edit, press the **Quit** Key.

1. Press the **Directory/Log** Key.
2. Press the **Directory** Key.

3. Use the **Navigation** Keys to scroll to and highlight the desired entry you want to delete.

Delete



Yes



or

No



Quit

4. Press **Delete** Key to delete the entire entry.

You are prompted to confirm deletion.

Press the **Yes** Key to delete the entire directory. Press the **No** Key to return to the top of the Personal Directory.

5. Press the **Quit** Key to exit the Personal Directory.

Delete your Personal Directory

Directory/Log



1. Press the **Directory/Log** Key.

Dir



DelList



Yes



2. Press the **Directory** Key.

3. Press the **Delete List** Key, the prompt is:
Delete all entries?

4. Press the **Yes** Key.

Note 1: If you press **Yes**, you delete all the entries in your Personal Directory.

Note 2: Press the **No** Key and you return to the top of the Personal Directory.

Use the Directory to make a call (M3904)

Follow these steps to make a call to a number listed in the directory:

Directory/Log



1. Press the **Directory/Log** Key.
2. Use the up or down **Navigation** Keys to highlight the desired name or number.
3. Press the **Dial** Key.



2498

Dial



Use Card View

The Card View provides additional information about the Directory entry. Select the Personal Directory.

To look at the Card View:



1. Select the **name**.
2. Press the right arrow **Navigation** Key to go to the Card View once you select the name.

To dial from Card View:



Dial



1. Use the **Navigation** Keys to show the name and number of the currently selected entry in the Card View.
2. Press the **Dial** Key to place the call.

To exit Card View:



Press the left arrow **Navigator** Key to leave the Card View and return to the selected name.

Copy a number from the Redial list to the Personal Directory (M3904)

Use the Copy Key to copy a number from the Redial List to the Personal Directory list.

To copy a number from the Redial list:



1. Press the **Directory/Log** Key.
2. Press the **Redial** Key.
3. Use the **Navigation** Keys to show the name and number you want to copy to your Personal Directory.

4. Press the **Copy** Key.

When you press the **Copy** Key, the prompt is: COPY to.

5. Press the **Personal Directory** Key.

6. Press the **Edit** Key.

or

7. Press the **Save** Key.

Note: The entry is saved to your Personal Directory and you are returned to the top of the Redial List.

Note: you can edit the name/number before you save to the Personal Directory or edit the text at a later time.

Operate the main features on the M3901

M3901 is a one line telephone. The M3901 operates in a different way than the other M3900 series Digital Telephones. This section explains in some detail the M3901 operation.

The M3901 supports five programmable features. You activate the features when you press the M3901 Feature Key and a dial pad number key for that feature. Your system administrator programs the features for your telephone. There is a feature card placed on your telephone, which lists the features and instructions.

M3901 Fixed Keys

Goodbye Key

List of Fixed Keys:



Press the **Goodbye** Key to terminate a call.
or

Replace the **handset** to terminate a call.

Hold Key

To put a call on Hold:



Press the **Hold** Key to put an active call on hold.

To take a call off Hold:



Press the **Line** (DN) Key to take the call off hold.

Note: When a call is on hold, the Message Waiting Call Status Indicator flashes to serve as a reminder.

Line Key

To use the Line Key to make a call:



or



1. Press the **Line** (DN) Key and **dial** the telephone number.

or



Lift the **handset**. The Line (DN) Key selects automatically.

2. **Dial** the telephone number.

Volume Control Bar

Raise or lower the volume on the ringer or handset:

To adjust the ring volume:



To adjust the ring or handset volume, press the **Volume Control Bar** rocker up or down.

Press the **Volume Control Bar** up or down while the telephone is ringing.

To adjust the handset volume (voice or dial tone):



Press the **Volume Control Bar** up or down when you can hear sound coming from the handset.

Features Key

To activate a feature:

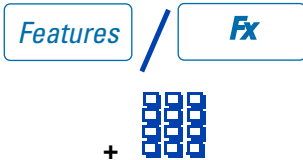

Press the **Features** Key plus a **dial** pad number key for that feature.

Use a programmed feature or an Auto Dial (M3901)

Your system administrator configures five features for your telephone.

To access a feature requires you to press the **Features** / **Fx** Key and a dial pad number key for that feature. You have 30 seconds to press the Feature Key and enter the key pad number for the feature or the process ends. Press the

Features / **Fx** Key and the **#** Key to turn an active feature off.

To activate Features:



1. Press the **Features** Key.



To deactivate Features:

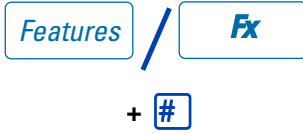

2. Press the **dial pad number key** that represents the feature you want to use.

Press the **Features Key** and the number Key to deactivate any active feature.

Note: The Features Card on the right side of the M3901 lists each feature and the dial pad number key used to activate the feature.

To program an Auto dial Key:

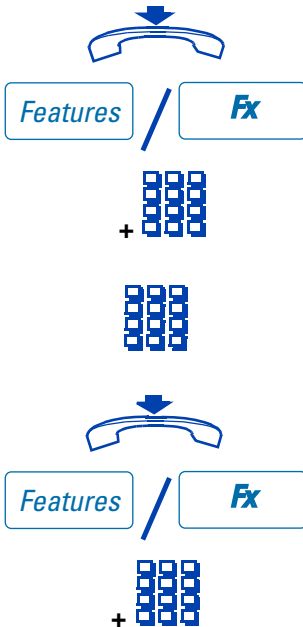

1. Press the **Features Key** and the **dial pad number key** for Auto Dial (handset is on-hook). The Feature Activation Indicator flashes.

2. **Dial** the desired number.

3. Press the **Features Key** and the **dial pad number key** for Auto Dial again.

To use Auto Dial (M3901)

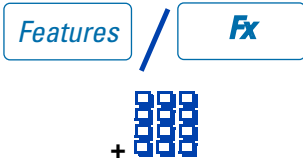

1. Lift the **handset** off-hook.
2. Press the **Features** Key and the **dial** pad number key for the Auto Dial.
The number dials automatically.

Use Speed Call (M3901)

To store a Speed Call Entry:

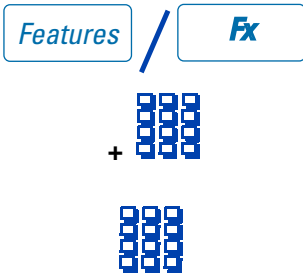

1. Press the **Features** Key and **dial** pad number key for Speed Call. The Feature Activation LED Indicator flashes.
2. **Dial** the Speed Call code 1 to 3 digits, followed by the telephone number it represents.
3. Press the **Features** Key and **dial** pad number key for Speed Call.

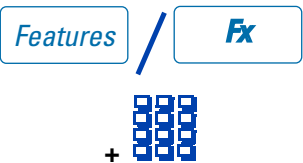

To make a Speed Call:

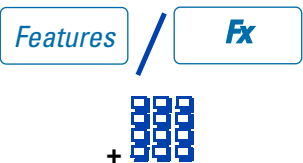

1. Lift the **handset**.
2. Press the **Features** Key and **dial** pad number key for Speed Call.



3. **Dial** the Speed Call code of the number you want to call.

The Speed Call feature automatically dials the number.

Use Call Transfer (M3901)

To transfer an active call you received to a different telephone follow these steps:

To use the Transfer feature:



1. Press the **Feature** Key and **dial** pad number key for Transfer.

2. **Dial** the number where you are transferring the call.



3. Press the **Feature** Key and **dial** pad number key for the Transfer Feature again when you hear the telephone at the other end ring.



4. Press the **Features Key** and **dial** the key pad number key for the Transfer Feature when the called party answers.

Note: On the Meridian SL-100 use steps one and two then hang up. If steps three and four are activated, a three way conversation is established.

Use Conference Call feature (M3901)

To add another party to an established call follow these steps:

To use the Conference Call feature:



1. Press the **Features** Key and the **dial** pad number key for Conference.

Note: The first party already on the line is automatically put on hold and you receive a dial tone.

2. **Dial** the number of the party you want to add to the call.

3. Press the **Feature** Key and the **dial** pad number key for Conference again to include all parties to the active call.

Note 1: To add more parties to the conference (up to six), repeat steps 1-3).

Note 2: Press the **Goodbye** Key, if you make an error while dialing the number or if you receive a busy signal, the Goodbye Key disconnects you from the call.

4. Press the **Line** (DN) Key to return to the original call.

Activate Ring Again (M3901)

If you receive a busy tone or no answer when you try to reach someone in your private network, Ring Again gives you audible tone notification when that person is available or has used their telephone. The Ring Again feature allows you to automatically redial the number.

To activate the Ring Again feature:



1. **Dial** a number and receive a busy tone or no answer.

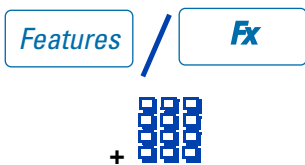

2. Press the **Features** Key and **dial** the key pad number for Ring Again.



3. Press the **Goodbye** Key.

To use Ring Again to call your party when you receive notification:



1. Press the **Line** (DN) Key when you hear the Ring Again tone.

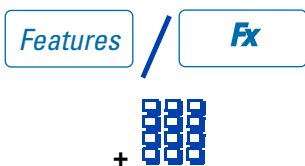

2. Press the **Feature** Key and **dial** the key pad number for the Ring Again feature. Ring Again dials the number.

To cancel the Ring Again feature:

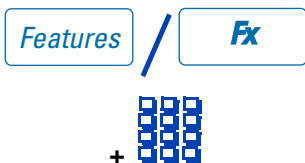

Press the **Feature** Key and **dial** key pad number for the Ring Again feature, before you hear the Ring Again notification tone.

Make a call (M3901)

To dial a number while on-hook:



1. Press the **Line** (DN) Key and **dial** the number. Use this method for on-hook dialing.



2. Lift the **handset** and speak when the party answers.



To use handset and dial number:



1. Lift the **handset**, the telephone automatically selects the DN line.
2. **Dial** the telephone number.

To terminate an active call:



Press the **Goodbye** Key.

Receive a call (M3901)

There is no separate status light for the Line or Directory Number (DN) Key. The Message Waiting Indicator (MWI) provides three functions. the MWI flashes for an incoming call, the MWI also flashes to indicate a call on Hold. The MWI produces a steady light to indicate a message waiting.

To receive a call:



Lift the **handset** when the telephone rings and begin to talk.

To terminate a call



Press **Goodbye** Key or replace handset to terminate the call.

Note: On M3901, the MWI LED flashes for an incoming call. The MWI is always active, there is not an option to turn it off.

Feature Activation Indicator (M3901)

The Feature Activation Indicator (FAI) serves all five programmable feature keys. The feature indicator LED winks or lights when a feature is active.

Message and Call Status Indicator (M3901)

The Message Waiting Indicator turns on to indicate a message waiting. The MWI is the indicator for an incoming call and the indicator for a call on hold. The MWI cannot show there is a message waiting if a call is on hold or if there is an incoming call.

Accessories for the M3900 Series telephone

Optional items are available for use with your M3900 Series Digital telephone. Please contact your System Administrator for additional details.

Note: Wall attachment is available for all four models.

Accessory Connection Module (ACM)

The Accessory Connection Module provides the interface for adding the Analog Terminal Adapter, External Alerter Interface, and Meridian Communication Adapter. The ACM is available for the M3902, M3903 and M3904.

Analog Terminal Adapter (ATA)

The ATA allows you to connect an analog device such as a modem or fax machine to your telephone. The ATA is available for the M3902, M3903, and M3904 models.

External Alerter and Recorder Interface

The External Alerter Interface lets you connect a remote ringer to your telephone. The External Alerter and Recorder interface is available for the M3902, M3903, and M3904 models.

Headsets

An amplified and unamplified headset is compatible with your M3900 Series Meridian Digital Telephones. The amplified headset is an option for noisy environments.

Headsets vary in electrical, physical and audio characteristics. Performance perception is subjective so it is recommended that the headset user try using their headset with each of the three settings on both internal and external calls to determine which works best for them.

To adjust the headset volume, go to the Options menu, Headset types and select one of the headset types from the sub-menu item: Headset 1, Headset 2 or Amplified.

Refer to your distributor for the latest product bulletin from Nortel Networks for recommended headset types for the M3900 Series telephone.

Key-based Expansion Module

The Key-based Add-on Module provides additional feature keys for the M3904. You can add up to two Key Expansion modules, for a total of 62 feature keys. The expansion modules are available for the M3904 telephone.

Meridian Communications Adapter (MCA)

The MCA lets you connect your telephone to a personal computer or terminal. You can use your telephone to exchange data between your computer and other computers. The MCA is compatible with all the M3902, M3903 and M3904 models.

Note: The Meridian SL-100 does not support the Meridian Communication Adapter.

Meridian 1 Flexible Feature Codes (FFC)

	Radio Paging		Lock
	Radio Paging Access		Unlock
	Radio Paging Answer		Call Pick Up
	Call Park		DN Pick Up
	Electronic Lock Password Change		Group Pick Up
	Maid ID		Remote Call Forward Activate
	Wake-Up Request		Remote Call Forward Verify
	Wake-Up Verify		Remote Call Forward Deactivate
	Wake-Up Cancel		Trace

Meridian SL-100 Feature Access Codes (FAC)

	Account Code		Make Set Busy (MSB)
	Anonymous Caller Rejection (ACRJ)		Malicious Call Hold (MCH)
	Automatic Callback (ACB)		Paging access code
	Automatic Recall (AR)		Random Make Busy (RMB)
	Busy Override		Secondary MADN Call Forwarding (CFMDN)
	Call Forward Busy/Don't Answer - Internal/External		Selective Call Forward (SCF)
	Customer Originated Trace (COT)		SIM Ring
	Directory Call Park (DCPK)		System Call Park
	Directed Call Pick-up (DCPU)		Station Origination Restrictions Controller (SORC)
	Executive Busy Override (EBO)		Station Specific AuthCode (SSAC)
	Flexible Station Controlled Conference (CNF)		Uniform Call Distribution (UCD)
	Last Number Redial		Wake-up Service

A

Accessory Connection Module (ACM) 107
 Account code 49
 Account feature code 30
 Activate Automatic Answerback 33
 Activate Override 54
 Analog Terminal Adapter (ATA) 107
 Area code setup 75
 Asterisk Key 60
 Attendant Recall 27
 Auto Dial 18
 Auto Dial (M3901) 98, 100
 Auto Dial Transfer 47
 Automatic Wake-Up 58

B

billing number 49
 buzz signal 47

C

Call Charge 29
 Call Conference feature (M3901) 102
 Call Forward 37
 Call indicator light 78
 Call Join 42
 Call Log 85
 Call log 7
 Call Log (M3903) 85
 Call Log (M3904) 86
 Call log option 74
 Call Page 48, 51
 Call Park 28
 Call party information 9

Call Pickup 34
 Call timer 75
 Call Transfer (M3901) 101
 Call Waiting 35
 Calling Party Number 29
 Camp-on, Forced 21, 22, 34, 38, 47, 51
 Card View 9, 94
 Centrex Switchhook Flash 31
 Centrex/Exchange Switchhook Flash 48
 Change a feature key label 69
 Charge a call or Charge a Forced call 49
 Conference call 42
 Contrast adjustment 71
 Controls, telephone 89
 Copy Key 6

D

Date/time display feature 9
 Delete Key 7
 Dial Key 6
 Dial Tone
 interrupted 9
 special 10
 Direct Inward System Access 39
 Directed Call Park (DCPK) Key 28
 Directed Call Pickup 35
 Directory Display 88
 Directory Number 9
 Directory Number (DN) 6
 Directory password protection 82
 Directory/Log 7

- Display 18, 31
- Display Diagnostics 76
- Display diagnostics 78
- Display Key 31
- DN 9
- E**
- Edit Key 7
- Electronic Lock 40
- Electronic Lock password 40
- Enhanced Override 51
- External Alerter and Recorder Interface 107
- F**
- Feature Access Codes (FAC) 9
- Feature Activation Indicator (M3901) 105
- Feature display 9
- Features Key 98
- Fixed key 9
- Flexible Feature Codes (FFCs) 9
- Forced Camp-on 21, 22, 34, 38, 47, 51
- G**
- Goodbye Key 5, 11, 97
- Group Call 44
- Group Intercom 57
- Group Listening 13
- Group listening 79
- H**
- Handset listen 72
- Handsfree 11
- Handsfree Button 11
- Handsfree listen 72
- Headset External Alerter and Recorder Interface 77
- Headset Key 5
- Headset listen 72
- Headset port on call 77
- Headset sidetone 72
- Headset talk 72
- Headsets 107
- Hold Key 5, 97
- Hold on Loudspeaker 52
- Hospitality features 58
- Hot Line 22
- I**
- Indicator status 9
- Information display 9
- Information line 9
- Intercom 23
- Intercom call 23
- Internal Call Forward 37
- Interrupted dial tone 9
- J**
- Join a call 42
- K**
- Key click 76
- Key-based Expansion Module 107
- L**
- Last Number Redial 20
- Line (DN) Key 5
- Line Key 97
- Live dial pad 74

M

M3901 Fixed Keys 97
 M3902 display 65
 M3903 display 65
 M3904 display 66
 Maid Identification 61
 Make a call (M3901) 103
 Make Busy 46
 Make Set Busy 46
 Malicious Call Hold (MCH) 31
 Meet - me" page 55
 Meridian 1 9
 Meridian 1 Flexible Feature Codes (FFC) 109
 Meridian Communications Adapter 79
 Meridian Communications Adapter (MCA) 108
 Meridian SL-100 Feature Access Codes (FAC) 110
 Message and Call Status Indicator (M3901) 105
 Message Registration 59, 60, 62
 More Key 7

N

Navigation Keys 6

O

Octothorpe Key 39
 Off-hook 10
 on-hook 18
 On-hook default path 78
 On-hook dialing 16
 Options Key 6

P

Paging tone 10
 Personal Directory 10, 88, 93
 Place a call on Hold 25
 Predial Recall 16
 Preferred name match 74
 Preset conference feature 44
 Primary Directory Number 6
 Primary Directory Number (DN) key 10
 Privacy Release 54
 Private Line 10
 Programmable Feature Keys 7
 Programmable Line/Feature Keys 8

Q

Quit Key 6

R

Receive a call (M3901) 104
 Redial Key 7
 Redial last number called 20
 Redial List 87
 Redial list 10, 15
 Redial List (M3903) 87
 Redial List (M3904) 87
 Redial list on the M3903 14
 Redial list on the M3904 15
 Remote Call Forward 38
 Ring Again 19
 Ring Again (M3901) 102
 Ring type 73
 Ringback/ring tone 9

S

Secure your telephone 40

- Select a language 69
 - Select options 67
 - Selectable Conferee display and Disconnect 43
 - Shared Directory Numbers 10
 - Shift Key 7
 - Speaker Key 5
 - Special dial tone 10
 - Speed Call 21
 - Speed Call (M3901) 100
 - Speed Call, System 22
 - SPRE code 29
 - Switchhook 8, 10
 - System Speed Call 22
- T**
- Timed Reminder Recall 26
 - Trace a Malicious call 31
 - Transfer a call 25
 - Trunk Switchhook Flash 48
- U**
- Use your Options 67
- V**
- Voice Call 56
 - Volume adjustment 72
 - Volume Control Bar 5, 98

Title to and ownership of Meridian SL-1 software shall at all times remain with Nortel Networks. Meridian SL-1 software shall not be sold outright and the use thereof by the customer shall be subject to the parties entering into software agreements as specified by Nortel Networks.

Information contained in this document is subject to change. Nortel Networks reserves the right, without notice, to make changes in equipment design or program components as progress in engineering, manufacturing or technology may warrant.

Reordering number: NT2F7901 A0779727
(c/o 15 each per package P0903627)

Internal Manufacturing part number:
P0903627
Issue 1.00

Printed in the United States of America
June 1999

www.nortelnetworks.com

NORTEL
NETWORKS