



Nortel Communication Server 1000

IP Phone 2007 User Guide



Revision history

February 2006

Preliminary 2.03. This document is up-issued to support Nortel Communications Server 1000 Release 4.5.

Note: The “Security features” section has a new “Secure communication” subsection. The LOGOS, copyright, and trademark information were updated.

August 2005

Standard 2.00. This document is up-issued to support Nortel Communication Server 1000 Release 4.5.

May 2005

Standard 1.00. This document is issued to support the IP Phone 2007 on Nortel Communication Server 1000 Release 4.0.

Contents

| | |
|---|-----------|
| About the Nortel IP Phone 2007 | 11 |
| Basic features | 12 |
| Telephone controls | 13 |
| Telephone display | 14 |
| Application area | 15 |
| Tools/Navigation area | 17 |
| Touch panel | 18 |
| Calibrate the touch panel | 19 |
| Stylus | 19 |
| Cleaning the Telephone Screen | 19 |
| Call features and Flexible Feature Codes | 19 |
| Security features | 19 |
| Secure Communication | 20 |
| Managing your Station Control Password (SCPW) | 20 |
| Enter and edit text | 23 |
| Enter text using the telephone dialpad | 23 |
| Edit text using the soft keys | 24 |
| Enter text using the pop-up keyboard | 24 |
| Enter text using the USB keyboard | 25 |
| Connect the IP Phone 2007 components | 26 |
| Before you begin | 26 |
| Steps | 26 |
| Configure IP Phone Local Options | 28 |
| Use Network Configuration | 28 |
| Use Local Diagnostics | 28 |
| Use Touch Panel Setup | 29 |

| | |
|--|-----------|
| Use Contrast and Brightness | 30 |
| Use USB Devices | 32 |
| Use TFTP Upgrade | 33 |
| Use Preferences | 34 |
| Configure services on the IP Phone 2007 | 37 |
| Use the Telephone Options menu | 38 |
| Adjust volume | 39 |
| Adjust display screen contrast | 43 |
| Telephone Options menu | 43 |
| Tools menu | 44 |
| Select a language | 44 |
| Telephone Options menu | 44 |
| Tools menu | 45 |
| Select Date/Time format | 45 |
| Display diagnostics | 46 |
| Choose Local DialPad Tone | 46 |
| View telephone information | 47 |
| Diagnostics | 47 |
| Configure call log options | 48 |
| Configure the Callers List log | 48 |
| Configure New Call indication | 50 |
| Configure Preferred Name Match | 51 |
| Configure Area Codes | 52 |
| Choose Ring type | 54 |
| Enable Call Timer | 55 |
| Enable OnHook Default Path | 55 |
| Change feature soft key labels | 56 |
| Configure Name Display format | 59 |

| | |
|---|-----------|
| Make a call | 61 |
| Use Off-hook dialing | 61 |
| Use On-hook dialing | 61 |
| Use Handsfree dialing | 62 |
| Use the Directory applications | 64 |
| Make a call using Corporate Directory | 64 |
| Make a call using Personal Directory | 66 |
| Make a call using Callers List | 66 |
| Make a call using Redial List | 67 |
| Use Predial | 68 |
| Use AutoDial | 69 |
| Activate Ring Again | 70 |
| Redial the last number called | 72 |
| Use Speed Call | 72 |
| Make a System Speed Call | 73 |
| Make a call using Hot Line | 74 |
| Make an Intercom call | 74 |
| Answer a call | 76 |
| While on an active call | 77 |
| Place a call on hold | 77 |
| Transfer a call | 77 |
| Use Timed Reminder Recall | 78 |
| Use Attendant Recall | 80 |
| Use Call Park | 80 |
| Record a Calling Party Number | 82 |
| Display incoming calls | 83 |
| Trace a Malicious call | 83 |

| | |
|---|------------|
| Incoming calls | 85 |
| Activate Automatic Answerback | 85 |
| Activate Call Pickup | 85 |
| Use Call Waiting | 87 |
| While away from your desk | 89 |
| Use Call Forward | 89 |
| Use Internal Call Forward | 90 |
| Use Remote Call Forward | 91 |
| Secure your telephone | 93 |
| Talk with more than one person | 95 |
| Use the Call Join feature | 95 |
| Set up a Conference call | 96 |
| Use the Conferee Selectable Display and Disconnect feature | 97 |
| Use Group Call | 98 |
| Work without interruption | 101 |
| Activate Make Set Busy | 101 |
| Additional call features | 102 |
| Use AutoDial Transfer | 102 |
| Use the Buzz signal | 103 |
| Use Call Page Connect to make an announcement | 103 |
| Use Centrex/Exchange Line Switchhook Flash | 104 |
| Charge a call or charge a forced call | 104 |
| Use Enhanced Override | 107 |
| Use Forced Camp-on feature | 108 |
| Override a busy signal | 110 |
| Use Privacy Release | 110 |

| | |
|--|------------|
| Use Radio Page | 111 |
| Use Voice Call | 113 |
| Additional features | 115 |
| Personal Directory | 115 |
| Callers List | 118 |
| Redial List | 119 |
| Virtual Office | 122 |
| Virtual Office login | 122 |
| Virtual Office on your office telephone | 124 |
| Virtual Office logout | 125 |
| Troubleshoot Virtual Office | 125 |
| Media Gateway 1000B | 128 |
| Test Local Mode | 128 |
| Resume Normal Mode | 129 |
| Troubleshoot MG 1000B | 129 |
| Hospitality features | 131 |
| Set Automatic Wake-Up | 131 |
| Activate Message Registration | 133 |
| Use Maid Identification | 134 |
| Display Room Status | 135 |
| External server applications | 138 |
| Flexible Feature Codes (FFC) | 139 |
| Regulatory and safety information | 141 |
| Other | 142 |
| Index | 143 |

About the Nortel IP Phone 2007

The Nortel IP Phone 2007 brings voice and data to the desktop by connecting directly to a Local Area Network (LAN) through an Ethernet connection.

The IP Phone 2007 provides all the functionality of the IP Phone 2004, using a graphical user interface (GUI). In addition, advanced text and graphic-based web-centric applications are supported.

The IP Phone 2007 does not support the IP Phone Key Expansion Module (KEM).

Some features are not available on all telephones. Consult your system administrator to verify which features are available for your use.

Basic features

The IP Phone 2007 supports the following features:

- 12 programmable feature soft keys
- four soft keys (self-labeled) providing access to a maximum of ten features

Note: Your IP Phone 2007 may not be configured to support soft key functionality. Consult your system administrator.

- speaker for on-hook dialing or on-hook listening
- volume control bar for adjusting ringer, speaker, handset, and headset volume
- four call processing fixed keys:
 - Hold
 - Goodbye
 - Handsfree
 - Mute
- shared LAN access with a PC
- headset jack with On/Off key
- automatic network configuration
- hearing-aid compatibility
- large, color touch panel display screen
- web-based applications support
- remote firmware download
- USB mouse and keyboard support

Telephone controls

Figure 1 shows the IP Phone 2007 controls.

Figure 1: IP Phone 2007.



Use the **Volume control** bar to adjust the volume of the ringer, handset, headset, speaker, and the Handsfree feature. Press the right side of the rocker bar to increase volume; press the left side to decrease volume.



Use the **Goodbye** key to terminate an active call.



Press the **Hold** key to put an active call on hold. Tap the flashing line (DN) soft key to return to the caller on hold.



Use the **Navigation** keys to scroll through menus and lists appearing on the LCD display screen. The key rocks for up, down, left, and right movements.



Press the **Headset** key to answer a call using the headset or to switch a call from the handset or handsfree to the headset.



Press the **Speaker** key to activate handsfree. The speaker LED indicator lights to indicate when handsfree is active.



Press the **Mute** key to listen to the receiving party without transmitting. Press the **Mute** key again to return to two-way conversation. The **Mute** key applies to handsfree, handset, and headset microphones. The Mute LED indicator flashes when the Mute option is in use.



When a message is left for the user, the **Message waiting indicator** flashes. Also, this indicator flashes when the set ringer is ON.



The two keys on either side of the navigation key are context-sensitive soft keys, with labels appearing on the display screen.

Telephone display

The IP Phone 2007 provides a large, color touch panel display that supports color XML/HTML content through an external application server.

The IP Phone 2007 window-based user interface has two display areas:

- Application area
- Tools/Navigation area

Figure 2 shows an example of an idle LCD display screen.

Figure 2: IP Phone 2007 LCD display screen

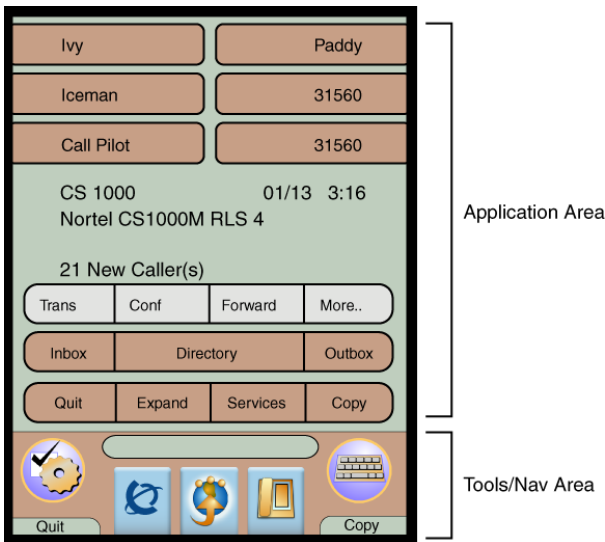

Note: The display can differ from the above example.

To extend the life of the LCD panel, the panel goes dark (“sleeps”) after a configured period of time. See “To use Contrast and Brightness” on page 30 for information on configuring the time before the telephone sleeps.

Application area

The Application area provides:

- line and feature soft key status
- information items such as caller number, caller name, feature prompt strings, user-entered digits, date and time information, and set information

- feature soft keys
- soft keys

Figure 3 shows the Application area.

Figure 3: IP Phone 2007 Application area

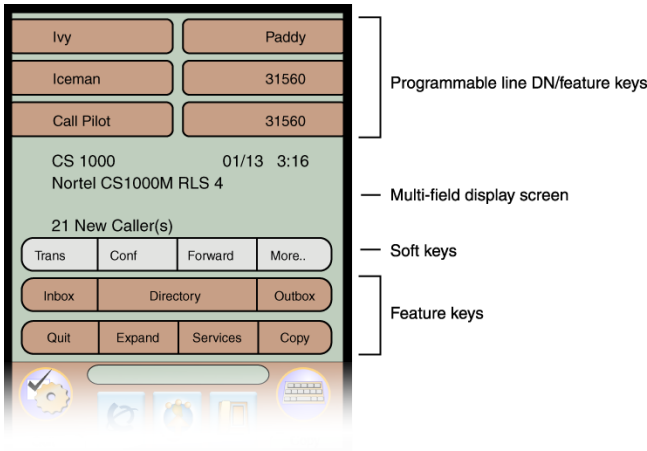



In the Feature area, the soft keys can show either text or icons. Table 1 shows the soft key text and icon equivalents. The text labels are displayed by default and are changed using the Tools menu (see “To use Button Customizing Tool” on page 34 for more information).

Table 1: Feature Key text and icon displays (Part 1 of 2)

| Text display | Icon display |
|--------------|--------------|
| Inbox | |
| Directory | |
| Outbox | |
| Quit | |
| Expand | |

Table 1: Feature Key text and icon displays (Part 2 of 2)

| Text display | Icon display |
|--------------|---|
| Services |  |
| Copy |  |

Tools/Navigation area

The Tools/Navigation area provides controls for navigating between features and selecting tools. This area is visible and functional at all times.

Figure 4 on page 17 shows the Tools/Navigation area.

Figure 4: IP Phone 2007 Tools/Navigation area

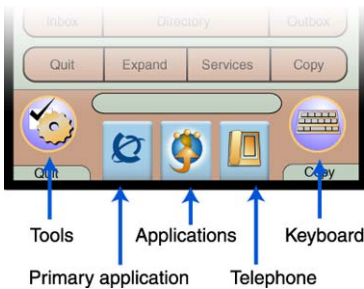

The Tools/Navigation area has five main elements presented as touchable soft keys:



Tap this icon to determine which external graphical applications are registered (for example, My CallPilot), and launch them by tapping on the appropriate icon.



Tap this icon to access the **Telephone** screen.



Tap this soft key to go to the primary graphical external application, as configured by the administrator. The soft key displays the icon of the primary graphical application.



Tap this icon to access the following tools used on the IP Phone 2007:

- Network Configuration
- Local Diagnostics
- Touch Panel Setup
- Contrast and Brightness
- USB Devices
- TFTP Upgrade
- Preferences



Tap this icon to display a virtual keyboard (pop-up keyboard) for text entry.

The pop-up or USB keyboards can be used to enter text in some of the applications. See “Enter and edit text” on page 23 for further information.

Touch panel

You perform point-and-click operations on your IP Phone 2007 using the touch panel. The touch panel is used with the graphical user interface (GUI) to present soft keys directly on the display. You can activate all Line/DN soft keys and feature soft keys by using the touch panel.

See “Cleaning the Telephone Screen” on page 19 for important information.

Calibrate the touch panel

You calibrate the touch panel through the **Tools** menu, which enables you to fine-tune the touch panel. You are prompted to use the stylus to tap three targets. See “To use Touch Panel Setup tool” on page 29 for further information.

Stylus

You operate the touch panel using a stylus or your finger. However, use of a stylus is recommended to avoid damage to the touch panel.

Cleaning the Telephone Screen

Hold down the **Goodbye** key, and then gently wipe the telephone screen with a soft, dry cloth.

**CAUTION**

Do not use any liquids or powders on the telephone.

Using anything other than a soft, dry cloth can contaminate telephone components and cause premature failure.

Call features and Flexible Feature Codes

System administration is required for call features and Flexible Feature Codes (FFCs). Contact your system administrator to configure these features and codes on your telephone.

The Call features and FFCs must be assigned to your telephone and supported by system software.

Security features

The following security features are available on your IP Phone 2007:

- Secure communication
- Managing your Station Control Password (SCPW)

Secure Communication

Your IP Phone 2007 supports secure communication using SRTP and a Pre-Shared Key (PSK) media encryption feature. If the feature is enabled, a security icon (🔒) appears on the screen when your call is secured using SRTP (PSK). Contact your system administrator to find out if this feature is enabled on your phone.

Managing your Station Control Password (SCPW)

Your Station Control Password (SCPW) enables the following security features:

- Electronic Lock to prevent others from making calls from your telephone.
- Password-protected telephone features (for example, Personal Directory, Callers List, and Redial List).

Your initial SCPW is defined by your system administrator. Please contact your system administrator for detailed information.

To change your SCPW



1. Tap the **Services** soft key.



2. Press the **Up/Down** keys to scroll and highlight **Password Admin**.



3. Tap the **Select** soft key.



4. Use the dialpad to enter your password at the prompt.



5. Press the **Up/Down** keys to scroll and highlight **New Password**.



6. Tap the **Select** soft key.



7. Use the dialpad to enter the new password.



8. Tap the **Select** soft key to accept the new password.

Note: If you are locked out of your IP Phone 2007 or forget your SPCW, contact your system administrator.

To turn Password Protection On/Off

Note:



1. Tap the **Directory** soft key.



2. Press the **Up/Down** navigation keys to scroll and highlight **Change Protection Mode**.



3. Use the dialpad to enter your password (if Password Protection is enabled).



4. Tap the **Enter** soft key.



5. Press the **Up/Down** navigation keys to scroll and highlight one of the following:
 - **Enable Password Protection**
 - **Disable Password Protection**

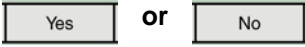

6. Choose one of the following:
 - **Yes** to accept the selection.
 - **No** to return to the **Directory** menu.



7. Tap the **Done** soft key.

Enter and edit text

You can enter and edit text on your IP Phone 2007 using the following methods:

- telephone dialpad
- soft keys
- pop-up keyboard
- USB keyboard (optional)

The use of any of these methods for text entry depends on the application. Table 2 shows the applications and input devices that can be used for text entry:

Table 2: Application Text Entry

| For: | Use: |
|---|--|
| Call Server related applications (for example, changing feature key labels, adding personal directory entries or for dialing) | Dialpad Pop-up or USB keyboard for numeric entries only |
| Graphical applications | Pop-up or USB keyboard |
| Tools menu | Pop-up or USB keyboard Dialpad for numeric entries |

Enter text using the telephone dialpad

You use the dialpad to enter text when you use features such as programming an AutoDial soft key.

For example, to enter the letter A, press the number **2** key once. To enter the letter C, press the number **2** key three times.

Note: No letters are associated with the number **1** or the number **0** key.

When entering IP addresses with the dialpad, the address is entered as xxx*xxx*xxx*xxx, and the telephone translates this to xxx.xxx.xxx.xxx.

Edit text using the soft keys

You use soft keys to access text when you work with such applications as Personal Directory, Redial List, and Callers List.

Table 3 describes the soft key editing functions on the IP Phone 2007.

Table 3: Editing soft key description

| Soft key | Description |
|-------------------|---|
| Cancel | Stop the current action.. |
| Choose | Select a symbol. |
| Clear | Clear the input field. |
| Case | Switch the next character to either uppercase or lowercase. |
| Delete | Backspace one character. |
| Done/Select/Enter | Depends on application. |
| More... | Access additional soft keys. |

Enter text using the pop-up keyboard

A full uppercase and lowercase keyboard and a number pad are available to enter text. The user can “type” on the keyboard with the stylus. The pop-up keyboard can be used to enter text in the tools and graphical applications.

For number entry in telephone applications (for example, when dialing), the keyboard can be used to enter digits (0–9), as well as star (*) and pound (#). Other characters are ignored.

Enter text using the USB keyboard

The USB keyboard, when connected, can be used to enter text in the tools and graphical applications.

For number entry in telephone applications (for example, when dialing), the keyboard may be used to enter digits (0–9), as well as * and #. Other characters are ignored.

When on a call, the function keys (f1, f2, f3, f4, f5, f6, f7, and f8) can be used to control the telephone. Table 4 shows the function keys and their associated action during telephone calls.

Table 4: USB keyboard function keys during telephone calls

| Function key | Action |
|--------------|--------------------------------|
| f1 | Go to Handsfree mode |
| f2 | Go to Headset mode |
| f3 | Place the current call on Hold |
| f4 | Mute the current call |
| f5 | Volume Up |
| f6 | Volume Down |
| f7 | Copy |
| f8 | Quit |

Connect the IP Phone 2007 components

Before you begin



CAUTION

Damage to Equipment

Do not plug the IP Phone 2007 into a regular telephone jack. This results in severe damage to the IP Phone. Consult your system administrator to ensure that you plug your set into a 10/100BaseT Ethernet jack.

Steps

1. Connect one end of the handset cord to the handset jack (identified with a handset icon) on the back of the telephone. Connect the other end to the jack on the handset.
2. Choose one of the following connections:
 - a. *For a telephone not sharing LAN access with a PC*, connect one end of the CAT5 line cable to the LAN Ethernet port located on the back of the telephone (identified with a LAN icon). Plug the other end of the CAT5 line cable into the IP network.
 - b. *For a telephone sharing LAN access with a PC*, connect one end of the CAT5 line cable to the LAN Ethernet port located on the back of the telephone (identified with a LAN icon) and the other end to the IP network. Insert a second CAT5 line cable into the PC Ethernet port located on the back of the telephone (identified with a PC icon) and the other end into the Ethernet port of the computer.

3. Contact your installation technician for the proper power option. This telephone can be powered by an optional AC adapter or using Power over Ethernet.



WARNING

If using an AC adapter, you must use the IP Phone 2007 Global Power Adapter (part number N0014020) or your phone will fail to operate.

4. Thread the cord around the strain relief, retaining hook, and channel provided for a secure power connection.
5. Secure the telephone footstand to the telephone base. Use the angle grip on the top back of the telephone to change position.
6. Contact your system administrator for configuration instructions.

Figure 5 shows connections on the IP Phone 2007.

Figure 5: IP Phone connections

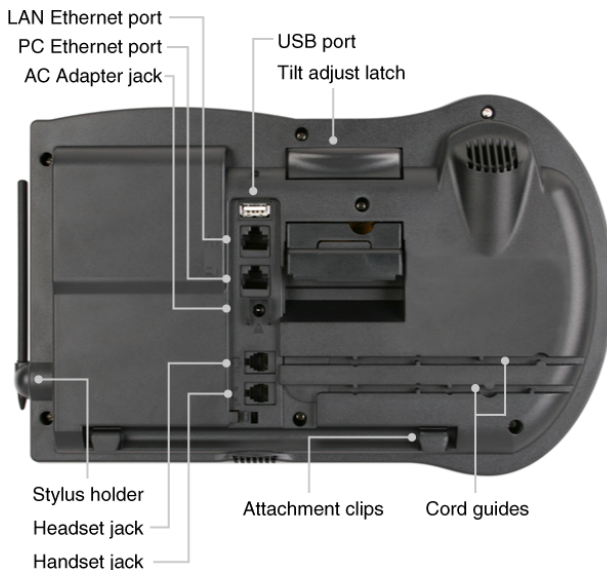

Configure IP Phone Local Options

Your IP Phone 2007 has both local and server-based options. The local options cover the following entries in the Tools menu:

- Network Configuration
- Local Diagnostics
- Touch Panel Setup
- Contrast and Brightness
- USB Devices
- TFTP Upgrade
- Preferences

Note 1: Many of the selections in the Tools menu are intended for system administrator use only.

Note 2: If Password Protection is enabled on your IP Phone 2007, you are prompted for a password when you open the Tools menu.

Entering text in the Tools menu items is easier with a USB keyboard.

Use Network Configuration

The Network Configuration displays the information that was configured when the telephone was installed. This tool is for administrator use only. See *IP Phones: Description, Installation, and Operation* (553-3001-368) for detailed instructions.

Use Local Diagnostics

The Local Diagnostic menu contains tools that are used to diagnose local problems. This menu is for administrator use only. See *IP Phones: Description, Installation, and Operation* (553-3001-368) for detailed instructions.

Use Touch Panel Setup

The Touch Panel Setup tool calibrates the touch panel and stylus. Calibration is required when stylus taps are not interpreted correctly.

To use Touch Panel Setup tool



1. Tap the **Tools** icon.

Touch Panel Set Up

2. Tap the **Touch Panel Setup** soft key.

The screen displays a calibration map, the **CANCEL** soft key is displayed, and the system prompts

Touch the center of the red ball.



3. Using the stylus, tap each of the dots, in order, starting with the red dot in the lower-left portion of the screen, and following the sequence as prompted.

4. After the third dot is tapped, the display changes to indicate the result of the calibration.

If the calibration is successful, the telephone reports

Data calibration is CORRECT, prompts Save Data Calibration?, and displays the **YES** and **NO** soft keys, and calibration statistics.

YES

NO

Choose one of the following:

- Tap the **YES** soft key to save the calibration settings and exit to the main display.
- Tap the **NO** soft key to abandon the calibration settings and exit to the main display.

5. If the calibration is not successful, the telephone reports Data calibration is **WRONG**, prompts Repeat Calibration?, and displays the **YES** and **NO** soft keys, and calibration statistics.

YES

NO

Choose one of the following:

- Tap the **YES** soft key to try the calibration again (starting at step 3).
- Tap the **NO** soft key to abandon the calibration and exit to the main display.

Use Contrast and Brightness

The Contrast and Brightness tools are used to alter the physical settings of the display.

To use Contrast and Brightness



Contrast and Brightness

1. Tap the **Tools** icon.
2. Tap the **Contrast and Brightness** soft key.

3. The screen displays:
 - Contrast, and a set of **Down** and **Up** soft keys
 - Brightness, and a set of **Down** and **Up** soft keys
 - Sleep in xxx, where xxx is a time in minutes or hours, and a set of **Down** and **Up** soft keys.



4. To increase the display contrast, tap the **Up** soft key beside the `Contrast` label.



5. To decrease the display contrast, tap the **Down** soft key beside the `Contrast` label.



6. To increase the display brightness, tap the **Up** soft key beside the `Brightness` label.



7. To decrease the display brightness, tap the **Down** soft key beside the `Contrast` label.

Up

8. To increase the time before the display sleeps (goes black), tap the **Up** soft key beside the `Sleep in` label. The sleep time increases from the default, and provides settings for:

5m (five minutes)

15m (15 minutes)

30m (30 minutes)

1h (one hour — default)

2h (two hours)

Never (screen does not go black).

Note: Extending the sleep time or never sleeping reduces the life span of the display screen.

Down

9. To decrease the time before the display sleeps (goes black), tap the **Down** soft key beside the `Sleep in` label. The time decreases from the default, and provides settings for:

Never (screen does not go black)

2h (two hours)

1h (one hour — default)

30m (30 minutes)

15m (15 minutes)

5m (five minutes).

Exit

10. Tap the **Exit** soft key to exit to the main display. Changes are saved automatically.

Use USB Devices

The USB Devices menu provides information about the Universal Serial Bus (USB) devices plugged into the USB port in the back of the telephone.

To use USB Devices



USB Devices

Exit

1. Tap the **Tools** icon.
2. Tap the **USB Devices** soft key.
The screen displays information about the device connected.
3. Tap the **Exit** soft key to exit to the main display.

Use TFTP Upgrade

The TFTP Upgrade menu is used to upgrade the firmware in the telephone. This menu is for administrator use only. See *IP Phones: Description, Installation, and Operation (553-3001-368)* for detailed instructions.

Use Preferences

Configure individual user preferences using the Preferences tool. The **Preferences** menu contains the **Button Customizing Tool** and the **Exit** soft key.

To use Button Customizing Tool



1. Tap the **Tools** icon.

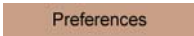

Preferences

2. Tap the **Preferences** soft key.

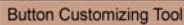

Button Customizing Tool

3. Tap the **Button Customizing Tool** soft key.

Three columns appear, labelled Buttons, Icons, and Labels:

Buttons

Icons

Labels

| |
|-----------|
| Inbox |
| Directory |
| Outbox |
| Quit |
| Expand |
| Services |
| Copy |

| |
|--|
| |
| |
| |
| |
| |
| |
| |

| |
|-------|
| ----- |
| ----- |
| ----- |
| ----- |
| ----- |
| ----- |
| ----- |

The boxes shown with a black outline are the current settings.

4. To change a soft key from displaying text to displaying the icon, tap the associated icon button. A black box appears around the icon.

Example: to change the soft key labeled Inbox on the main display to the icon, tap the Inbox icon.

5. To change a soft key to display a custom label:
 - a. Tap twice on the corresponding field in the Label column; a blinking cursor appears, and a black box appears around the label.
 - b. Enter text by typing on the USB keyboard or virtual keyboard.
 - c. Tap somewhere on the screen to stop editing the field.

Note: The system truncates the label if the text does not fit into the display area of the soft key.

Apply

or

Exit

Yes

or

No

Exit

6. Choose one of the following:

- To apply the changes, tap the **Apply** soft key. The system responds *Saving is in progress* and then *Saving is complete*.
- To abandon the changes, tap the **Exit** soft key. The system responds *Save changes?* and the **Yes** and **No** soft keys display.

Choose one of the following:

- Tap the **Yes** soft key to save the changes.
- Tap the **No** soft key to abandon the changes and exit to the Preferences menu.

7. Tap the **Exit** soft key to return to the Preferences menu.

To exit from the Preferences menu

Exit

Tap the **Exit** soft key to return to the main display.

Configure services on the IP Phone 2007

The IP Phone 2007 **Services** menu lists the following submenus:

- The **Telephone Options** menu enables you or your system administrator to configure telephone preferences.
- The **Password Admin** menu enables you or your system administrator to change the Station Control Password.
- The **Virtual Office Login** and **Test Local Mode** (for branch office) menus are listed when an IP Phone 2007 Class of Service is set for Virtual Office and branch office. For more information, see “Virtual Office” on page 122.

Note: The **Password Admin**, **Virtual Office Login**, and **Test Local Mode** menus may not be available on your IP Phone 2007. Consult your system administrator.

The **Telephone Options** menu offers the following menu options:

- Volume adjustment...
- Contrast adjustment
- Language...
- Date/Time
- Display diagnostics
- Local DialPad Tone
- Set Info
- Diagnostics
- Call Log Options
- Ring type...
- Call timer
- OnHook default path
- Change FeatureKey label

- Name Display Format

Note: When an option has a sublist, an ellipsis (...) appears after the option.

In the **Services** menu, the current setting for options is marked with a telephone icon.

Because this menu comes from the Call Server, use the **Up/Down** navigation keys for scrolling and tap the **Select** soft key.

Use the Telephone Options menu

To use the Telephone Options menu



1. Tap the **Services** soft key.



2. Press the **Up/Down** navigation keys to scroll and highlight **Telephone Options**.



3. Tap the **Select** soft key.



4. Press the **Up/Down** navigation keys to scroll and highlight an option (for example, **Language...**).



5. Tap the **Select** soft key. The display provides information required to adjust your selection.

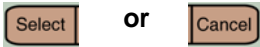

6. Choose one of the following:
 - Tap the **Select** soft key to save changes and return to the **Telephone Options** menu.
 - Tap the **Cancel** soft key to keep existing settings.

Adjust volume

To adjust the volume, tap the **Services** soft key, select **Telephone Options**, and select **Volume adjustment...** from the menu. Choose one of the following:

- Ringer
- Handset listen
- Handsfree listen
- Headset listen
- Buzzer

To adjust Ringer volume



1. Press the **Up/Down** navigation keys to scroll and highlight **Ringer**.

2. Tap the **Select** soft key.
The phone rings.

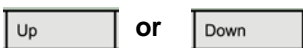

3. To increase or decrease the volume, choose one of the following:
 - Tap the **Up** or **Down** soft keys.
 - Press the **Up/Down** navigation keys.

4. Choose one of the following:
 - Tap the **Select** soft key to save the changes and return to the **Telephone Options** menu.
 - Tap the **Cancel** soft key to keep existing settings.

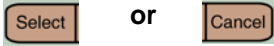

To adjust Handset listen volume



1. Press the **Up/Down** navigation keys to scroll and highlight **Handset listen**.



2. Tap the **Select** soft key.

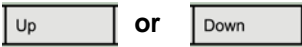

3. To increase or decrease the volume, choose one of the following:

- Tap **Up** or **Down** soft keys.
- Press the **Up/Down** navigation keys.



4. Choose one of the following:
 - Tap the **Select** soft key to save the changes and return to the **Telephone Options** menu.
 - Tap the **Cancel** soft key to keep existing settings.

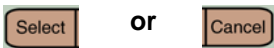

To adjust the Handsfree listen volume



1. Press the **Up/Down** navigation keys to scroll and highlight **Handsfree listen**.



2. Tap the **Select** soft key.

3. To increase or decrease the volume, choose one of the following:

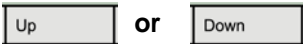

- Tap the **Up** or **Down** soft keys.



- Press the **Up/Down** navigation keys.

4. Choose one of the following:

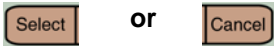

- Tap the **Select** soft key to save the changes and return to the **Telephone Options** menu.

- Tap the **Cancel** soft key to keep existing settings.

To adjust the Headset listen volume



1. Press the **Up/Down** navigation keys to scroll and highlight **Headset listen**.



2. Tap the **Select** soft key.

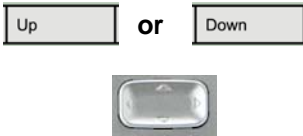

3. To increase or decrease the volume, choose one of the following:
 - Tap the **Up** or **Down** soft keys.
 - Press the **Up/Down** navigation keys.

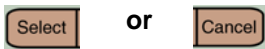

4. Choose one of the following:
 - Tap the **Select** soft key to save the changes and return to the **Telephone Options** menu.
 - Tap the **Cancel** soft key to keep existing settings.

To adjust the Buzzer volume



1. Press the **Up/Down** navigation keys to scroll and highlight **Buzzer**.



2. Tap the **Select** soft key.
The buzzer sounds.

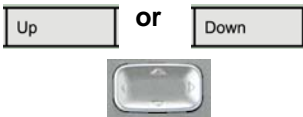

3. To increase or decrease the volume, choose one of the following:
 - Tap the **Up** or **Down** soft keys.
 - Press the **Up/Down** navigation keys.

4. Choose one of the following:

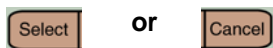

- Tap the **Select** soft key to save the changes and return to the **Telephone Options** menu.
- Tap the **Cancel** soft key to keep existing settings.

Adjust display screen contrast

There are two ways to adjust the display screen contrast:

- **Services** > **Telephone Options** menu
- **Tools** menu

Telephone Options menu

To adjust the LCD display screen contrast, tap the **Services** soft key, select **Telephone Options**, and select **Contrast adjustment** from the menu.

To adjust display screen contrast

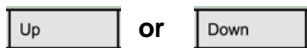

1. To increase or decrease the display contrast level, choose one of the following:

- Tap the **Up** or **Down** soft keys.
- Press the **Up/Down** navigation keys.

2. Choose one of the following:



or



- Tap the **Select** soft key to save the changes and return to the **Telephone Options** menu.
- Tap the **Cancel** soft key to keep existing settings.

Tools menu

The **Tools** menu method lets you adjust the contrast when the phone is not connected to a call server. See “Use Contrast and Brightness” on page 30 for the procedure.

Select a language

The display is available in multiple languages. The language for parts of the display are locally configured using the Tools menu, while others are configured through the call server.

Telephone Options menu

To choose a language, tap the **Services** soft key, select **Telephone Options**, and select **Language...** from the menu.

To select a language



1. Press the **Up/Down** navigation keys to scroll and highlight the desired language (for example, German [Deutsche]).

2. Choose one of the following:
 - Tap the **Select** soft key to save the desired language and return to the **Telephone Options** menu.
 - Tap the **Cancel** soft key to keep existing settings.

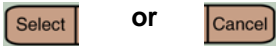

Tools menu

Use the procedure described in “Use Preferences” on page 34 to change the language for the local labels of the graphical user interface.

Select Date/Time format

Several Date/Time formats are available. Formats are based on the 12-hour and 24-hour clocks. To select a date and time format, tap the **Services** soft key, select **Telephone Options** and choose **Date/Time...** from the menu.

To select date and time



1. Press the **Up/Down** navigation keys to scroll and highlight the desired format. Sample formats appear on the upper-right side of the display area.
2. Choose one of the following:
 - Tap the **Select** soft key to save the format and return to the **Telephone Options** menu.
 - Tap the **Cancel** soft key to keep existing settings.

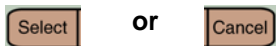

Display diagnostics

The Display diagnostics option tests the telephone display screen and indicator lights. To access Display diagnostics, tap the **Services** soft key, select **Telephone Options**, and select **Display diagnostics** from the menu.

To select Display diagnostics



1. Press the **Up/Down** navigation keys to scroll through the list to view display capabilities.



or



2. Tap the **Cancel** or **Quit** soft key to return to the **Telephone Options** menu.

Choose Local DialPad Tone

The Local DialPad Tone option produces Dual-Tone Multi-Frequency (DTMF) sounds, a single tone, or no sound when you press a key on the dialpad. To choose a Local DialPad Tone, tap the **Services** soft key, select **Telephone Options**, and select **Local DialPad Tone** from the menu.

To choose a Local DialPad Tone



1. Press the **Up/Down** navigation keys to scroll and highlight one of the following dialpad tones:
 - **None** to disable all tones.
 - **Short Click** to enable a single tone for all keys.
 - **DTMF** to turn on a separate DTMF tone for each key.

2. Choose one of the following:

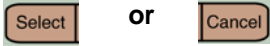

- Tap the **Select** soft key to save the tone selection and return to the **Telephone Options** menu.
- Tap the **Cancel** soft key to keep existing settings.

View telephone information

The Set Info option displays the following:

- General Information
- Set IP Information
- Ethernet Information
- Server Information

To view telephone information, tap the **Services** soft key, select **Telephone Options**, and select **Set Info** from the menu.

To view telephone information



1. Press the **Up/Down** navigation keys to scroll through the list to view telephone information.



2. Tap the **Cancel** soft key to return to the **Telephone Options** menu.

Diagnostics

Choosing the diagnostics option in the Telephone Options menu presents the user with a screen that indicates the option is unsupported. The **OK** soft key is presented.

Configure call log options

Use the Call Log option to configure the following preferences:

- Incoming Calls
 - Log Mode
 - New Call Indication
- Preferred Name Match
- Area code setup

Configure the Callers List log

You can configure the Callers List to log all incoming calls or only unanswered calls. The default setting is “Log all calls”. To log only unanswered calls, tap the **Services** soft key, select **Telephone Options**, and select **Call Log Options** from the menu.

To log only unanswered calls



1. Press the **Up/Down** navigation keys to scroll and highlight the **Incoming Calls** option.



2. Tap the **Select** soft key.



3. Press the **Up/Down** navigation keys to scroll and highlight the **Log Mode** option.



4. Tap the **Select** soft key.



5. Press the **Up/Down** navigation keys to scroll and highlight **Log unanswered calls**.



or



6. Choose one of the following:
 - Tap the **Select** soft key to save the setting.
 - Tap the **Cancel** soft key to keep existing settings.

To log all calls



1. Press the **Up/Down** navigation keys to scroll and highlight the **Incoming Calls** option.



2. Tap the **Select** soft key.



3. Press the **Up/Down** navigation keys to scroll and highlight the **Log Mode** option.



4. Tap the **Select** soft key.



5. Press the **Up/Down** navigation keys to scroll and highlight **Log All Calls**.



or



6. Choose one of the following:
 - Tap the **Select** soft key to save the setting.
 - Tap the **Cancel** soft key to keep existing settings.

Configure New Call indication

You can configure the IP Phone 2007 to display a message to indicate a new incoming call was received. The default setting is “ON.” To configure New Call indication, tap the **Services** soft key, select **Telephone Options**, and select **Call Log Option** from the menu.

To configure New Call indication



1. Tap the **Select** soft key to select **Incoming Calls**.



2. Press the **Up/Down** navigation keys to scroll and highlight **New Call Indication**.



3. Tap the **Select** soft key.



4. Press the **Up/Down** navigation keys to scroll and highlight one of the following:
 - **New call indication:On**
 - **New call indication:Off**

- Choose one of the following:



or



- Tap the **Select** soft key to save the setting.
- Tap the **Cancel** soft key to keep existing settings.

Configure Preferred Name Match

You can configure the IP Phone 2007 to display the name of the caller as defined in your Personal Directory. The default setting is “OFF.” To configure Preferred Name Match, tap the **Services** soft key, select **Telephone Options**, and select **Call Log Option** from the menu.

To configure Preferred Name Match



- Press the **Up/Down** navigation keys to scroll and highlight **Preferred Name Match**.



- Tap the **Select** soft key.



- Press the **Up/Down** navigation keys to scroll and highlight one of the following:

- **Pref Name Match: On**
- **Pref Name Match: Off**

- Choose one of the following:



or



- Tap the **Select** soft key to save the setting.
- Tap the **Cancel** soft key to keep existing settings.

Configure Area Codes

The Area Code Setup menu enables a user to save up to three area codes. When an incoming call arrives with an area code that matches one of the three stored area codes, the incoming call number is reordered to display the telephone number followed by the area code (as opposed to the area code followed by the telephone number).

This reordering is also performed when a user scrolls through their Callers List.

To configure an area code, tap the **Services** soft key, select **Telephone Options**, and select **Call Log Option** from the menu.

To configure default area codes (three maximum)



1. Press the **Up/Down** navigation keys to scroll and highlight **Area Code Setup**.



2. Tap the **Select** soft key.



3. Press the **Up/Down** navigation keys to scroll and highlight one of the following:
 - **1st Code:**
 - **2nd Code:**
 - **3rd Code:**



4. Tap the **Select** soft key.



5. Use the dialpad to enter the new area code at the prompt.



or



6. Choose one of the following:
 - Tap the **Select** soft key to save the setting.
 - Tap the **Cancel** soft key to keep the existing settings.

To edit area code display



1. Press the **Up/Down** navigation keys to scroll and highlight **Area Code Setup**.



2. Tap the **Select** soft key.



3. Press the **Up/Down** navigation keys to scroll and highlight one of the following:
 - **1st Code:**
 - **2nd Code:**
 - **3rd Code:**



4. Tap the **Select** soft key.



5. Use the **Clear** soft key to clear the area code.



6. Use the dialpad to enter the new area code, using the **Delete** soft key to remove errors.



or



7. Choose one of the following:
 - Tap the **Select** soft key to save the setting.
 - Tap the **Cancel** soft key to keep existing settings.

Choose Ring type

The Ring type option sets the telephone ring tone. To choose a ring type, tap the **Services** soft key, select **Telephone Options**, and select **Ring type...** from the menu.

To select a Ring type



1. Press the **Up/Down** navigation keys to scroll and highlight one of the ring types.



2. Tap the **Play** soft key to hear the ring tone.



3. Tap the **Stop** soft key to stop the tone.



4. Choose one of the following:
 - Tap the **Select** soft key to save the ring type and return to the **Telephone Options** menu.



- Tap the **Cancel** soft key to keep existing settings.

Enable Call Timer

The Call Timer measures the length of each call. To enable Call Timer, tap the **Services** soft key, select **Telephone Options**, and select **Call Timer** from the menu.

To enable Call Timer



1. Press the **Up/Down** navigation keys to scroll and highlight either:
 - **Call timer: Off**
 - **Call timer: On**

2. Choose one of the following:
 - Tap the **Select** soft key to save the setting and return to the **Telephone Options** menu.
 - Tap the **Cancel** soft key to keep existing settings.



or



Enable OnHook Default Path

The OnHook Default Path option allows you to use a headset or the Handsfree feature to operate your IP Phone while it is on-hook. To enable OnHook Default Path, tap the **Services** soft key, select **Telephone Options**, and select **OnHook Default Path** from the menu.

To enable OnHook Default Path



1. Select one of the following:
 - **Handsfree enabled**
 - **Headset enabled**

2. Choose one of the following:



or



- Tap the **Select** soft key to save your choice.
- Tap the **Cancel** soft key to keep existing settings.

Change feature soft key labels

The Change FeatureKey label option renames the label displayed next to each feature soft key or restores the default labels to the soft keys (collectively or individually). To rename feature soft key labels, tap the **Services** soft key, select **Telephone Options**, and select **Change FeatureKey labels** from the menu.

Note: If a feature soft key is configured as an autodial soft key, the label does not change if the AutoDial soft key configuration changes.

To change a label



1. Tap the **Select** soft key.



2. Use the **Up/Down** navigation keys to scroll to highlight Change FeatureKey label.



3. Tap the **Select** soft key.

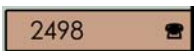

4. Tap the feature soft key to be changed.

Note: If you tap a prime DN soft key, an error message displays.



5. Enter the new information for the feature soft key label. For information about entering text, refer to “Enter text using the telephone dialpad” on page 23.

Note: Press the key until the desired character is displayed, then wait until the cursor moves before entering the next character.

Use the **More..** soft key and the **CASE** or **case** soft keys to toggle between uppercase and lowercase.



6. To enter special characters, press the **Up** or **Down** navigation key to display several sets of special characters.

Note: When choosing the special characters, use the navigation keys to move right or left, until the cursor is immediately before the desired character.



7. Choose one of the following:

- Tap the **Select** soft key to save the changes and return to the **Telephone Options** menu.
- Tap the **Cancel** soft key to keep existing settings.

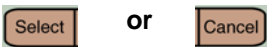

Restore all the default labels

To restore all feature soft key labels, tap the **Services** soft key, select **Telephone Options**, and select **Change FeatureKey labels** from the menu.



1. Tap the **Select** soft key.



2. Use the **Up/Down** navigation keys to scroll and highlight **Restore all key labels**.

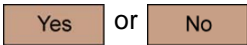

3. Choose one of the following:

- Tap **Yes** to change all feature soft keys to default values.

Note: When labels are changed to default values, you cannot undo the change. The label settings must be re-entered.

- Tap **No** to exit without changing the soft keys.

Restore one default label

To restore one feature soft key label, tap the **Services** soft key, select **Telephone Options**, and select **Change FeatureKey labels** from the menu.



1. Tap the **Select** soft key.



2. Use the **Up/Down** navigation keys to scroll and highlight Restore one key label.



3. Tap the **Select** soft key.

4. Tap the feature soft key.

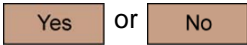

5. Choose one of the following:
 - Tap **Yes** to change the feature soft keys to default values.

Note: When a label is changed to default values, you cannot undo the change. The label setting must be re-entered.

- Tap **No** to exit without changing the soft key.

Configure Name Display format

You can configure the IP Phone 2007 to display the name of the incoming calling party in the following formats:

- first name, last name
- last name, first name

To configure Name Display format, tap the **Services** soft key, and select **Telephone Options**.

To configure Name Display format



1. Press the **Up/Down** navigation keys to scroll and highlight **Name Display format**.



2. Tap the **Select** soft key.



3. Press the **Up/Down** navigation keys to scroll and highlight one of the following:
 - **last name, first name**
 - **first name, last name**



or



4. Choose one of the following:
 - Tap the **Select** soft key to save the setting.
 - Tap the **Cancel** soft key to keep existing settings.

Make a call

This section describes features associated with making a call. There are several ways to make a call from an IP Phone 2007.

Use Off-hook dialing



1. Lift the handset.



2. Dial the number.

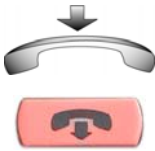

3. To terminate the call, choose one of the following:
 - Replace the handset into the cradle.
 - Press the **Goodbye** key.

Use On-hook dialing

1. Leave the handset in the cradle.

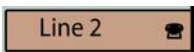

2. Tap the line (DN) soft key.



3. Dial the number when the dial tone sounds.



4. When the called party answers, lift the handset.

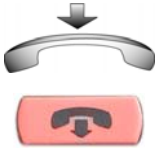

5. To terminate the call, choose one of the following:
- Replace the handset into the cradle.
 - Press the **Goodbye** key.

Use Handsfree dialing

Use Handsfree dialing to use a built-in microphone and speaker, or a headset, instead of the handset. While on an active call, you can switch between Handset and Handsfree mode.



1. Press the **Handsfree** key.



2. If a headset is connected, press the **Headset** key.



3. Dial the number.

To discontinue a handsfree call



Press the **Goodbye** key.

To mute a handsfree call



1. Press the **Mute** key. The LED indicator flashes.



2. Press the **Mute** key again to return to a two-way handsfree conversation.

To switch from Handsfree mode to Handset mode



Lift the handset.

To switch from Handset mode to Handsfree mode



1. Press the **Handsfree** key.



2. Replace the handset.

To use a headset

1. Connect the headset to the headset jack or the handset jack.



2. Press the **Headset** key.

To switch from Handsfree mode to Headset mode



Press the **Headset** key.

Use the Directory applications

You can make calls using various Directory applications available on your IP Phone 2007. The applications include:

- Corporate Directory
- Personal Directory
- Callers List
- Redial List

Make a call using Corporate Directory

The Corporate Directory feature provides an alphabetical list of entries using last names. You can search by name, view additional information on each entry, and dial Corporate Directory numbers. To use Corporate Directory, tap the **Directory** soft key and select **Corporate Directory**.

To search for a specific number



1. When prompted, use the dialpad to enter the desired name in the last name, first name format.



2. Tap the **Search** soft key to find the desired name.

A list of all the matches displays.



3. Press the **Up/Down** navigation keys to scroll and highlight a name in the Corporate Directory.



4. Choose one of the following:

- Tap the **Dial** soft key to dial the resulting number.
- If there is no match to the search query, start a new search or change the information in the initial search.
- Tap the **Cancel** soft key to exit without dialing.



Make a call using Personal Directory

The Personal Directory feature allows you to store a maximum of 100 entries consisting of names and numbers. To use Personal Directory, tap the **Directory** soft key and select **Personal Directory**. For more information on how to configure and use Personal Directory, refer to “Personal Directory” on page 115.

To use the Personal Directory



1. Press the **Up/Down** navigation keys to scroll and highlight a name in the **Personal Directory**.

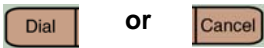

2. Choose one of the following:
 - Tap the **Dial** soft key to dial the resulting number.
 - Tap the **Cancel** soft key to exit without dialing.

Make a call using Callers List

The Callers List feature automatically stores up to a maximum of 100 callers. After 100 callers are stored, each additional caller overwrites the oldest entry. To use Callers List, tap the **Directory** soft key and select **Callers List**. For information on how to configure and use Callers List, refer to “Callers List” on page 118.

To use the Callers List



1. Press the **Up/Down** navigation keys to scroll and highlight a name in the **Callers List**.

2. Choose one of the following:

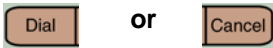

- Tap the **Dial** soft key to dial the resulting number.
- Tap the **Cancel** soft key to exit without dialing.

Make a call using Redial List

The Redial List feature automatically stores a maximum of 20 previously dialed telephone numbers. To use Redial List, tap the **Directory** soft key and select **Redial List**. For information on how to configure and use Redial List, refer to “Redial List” on page 119.

To use the Redial List



1. Press the **Up/Down** navigation keys to scroll and highlight a name in the **Redial List**.

2. Choose one of the following:

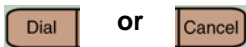

- Tap the **Dial** soft key to dial the resulting number.
- Tap the **Cancel** soft key to exit without dialing.

Use Predial

Use the Predial feature to enter, preview, and edit numbers before dialing.

To use Predial



1. Without selecting the line soft key, enter the number to be dialed.



2. Tap a line soft key to dial the number.



3. Lift the Handset when the called party answers or, if in Handsfree mode, begin to speak.

To edit a Predial number



1. Use the dialpad to enter the number.

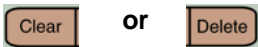

2. Choose one of the following:
 - To erase all numbers, tap the **Clear** soft key. Re-enter the numbers to be dialed.
 - To change numbers one at a time, tap the **Delete** soft key to backspace. Re-enter the number.

2498

3. Tap a line soft key to dial the number.

Use AutoDial

Use the AutoDial feature to display, store, and automatically dial telephone numbers.

To store an AutoDial number

AutoDial

1. Without lifting the handset, tap the appropriate **AutoDial** soft key.

Note: The display screen displays the word “Autodial” next to the appropriate soft key.



2. Using the dialpad, dial the telephone number (including access code) to be stored on the selected **AutoDial** soft key.

AutoDial

3. Tap the **AutoDial** soft key a second time to store the number on the selected soft key.

Note: Once a number has been stored, the word “Autodial” disappears, and the stored number displays.

4. Assign a label to the soft key.

Note: After the label is assigned, the number disappears and only the label appears on the screen next to the soft key.

To display an AutoDial number



1. Tap the **Display** soft key. Telephone Options



2. Tap an **AutoDial** soft key in the upper display area to display the number associated with that soft key.

To use AutoDial



1. Lift the handset.



2. Tap an **AutoDial** soft key in the upper display area to dial the number associated with that soft key.

Activate Ring Again

Use the Ring Again feature if you receive a busy tone, or if there is no answer. Your IP Phone rings when the person you called becomes available. Ring Again automatically redials the number.

To activate Ring Again



1. Dial a number and receive a busy tone or no answer.

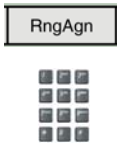

2. Choose one of the following:
 - Tap the **Ring Again** soft key.
 - Enter the Ring Again Activate FFC.

To call a Ring Again party when you receive notification



1. After receiving the notification ring, lift the handset, or if you are using the headset, go to Step 2.
2. Tap the **Ring Again** soft key to automatically dial the number.



To deactivate Ring Again before notification



- Choose one of the following:
- Tap the **Ring Again** soft key a second time.
 - Enter the Ring Again Deactivate FFC.

Redial the last number called

Use the Last Number Redial feature to automatically redial the last dialed number.

To use Last Number Redial

Choose one of the following:



1. To redial using the handset:
 - a. Lift the handset.
 - b. Tap the line (DN) soft key.



2. To redial without lifting the handset, tap the line (DN) soft key twice (the last number dialed is automatically redialed).

Use Speed Call

Use the Speed Call feature to place internal and external calls by dialing a one-, two-, or three-digit code to store, edit, and automatically dial frequently called telephone numbers.

To store a Speed Call number



1. Tap the **Speed Call Controller** soft key. The triangular icon flashes, indicating programming mode.



2. At the prompt:
 - Enter a one-, two-, or three-digit code (0-999).
 - If required, dial the access code.



3. Tap the **Speed Call Controller** soft key again to save the code and number. The flashing icon turns off.

To make a Speed Call



1. Lift the handset.



2. Tap the **Speed Call Controller** soft key.



3. Dial the Speed Call code to automatically dial the number.

Make a System Speed Call

Use the System Speed Call feature to dial Speed Call codes that override dialing restrictions placed on your telephone.

To make a System Speed Call



1. Lift the handset.

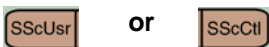

2. Choose one of the following:
 - Tap the **System Speed Call (SScUsr)** soft key.
 - Tap the **System Speed Call Controller (SScCtl)** soft key.



3. Dial the Speed Call code to automatically dial the number.

Make a call using Hot Line

Use the Hot Line feature to automatically dial a specific number.

To use Hot Line



- Tap the **Hot Line** soft key to automatically dial the number.

Make an Intercom call

Use the Intercom feature to call a member of your intercom group by tapping the code assigned to each member.

To make an Intercom call



1. Lift the handset.



2. Tap the **Intercom** soft key.



3. Dial the one- or two-digit code for the desired intercom group member.

To answer an Intercom call while on a line other than your Intercom group line



1. Choose one of the following keys:
 - Press the **Hold** key to put the current call on hold.
 - Press the **Goodbye** key to end the call.
2. Tap the **Intercom** soft key and begin to speak.

Answer a call

Each incoming call causes the telephone to ring, the line/DN soft key to flash and show a , and the Message Indicator lamp to flash.

To answer a call

Choose one of the following:



- Lift the handset.
- Press the **Handsfree** button located on the left side of the handset.
- Tap the line (DN) soft key beside the LCD indicator as it flashes.
- Press the **Headset** key if a headset is connected to your telephone.

While on an active call

This section describes features available during an active call.

Place a call on hold

Use the Hold feature when talking on one line and another call arrives on a second line. Retain the original call by putting it on hold, and then answer the second call.

To place a call on hold



Press the **Hold** key. The LCD indicator flashes beside the line on hold.

Note: If Automatic Hold is enabled, the active call is automatically put on hold when you answer the second call.

To retrieve a call on hold



Tap the flashing line (DN) soft key.

Transfer a call

Use the Transfer feature to redirect a call to the appropriate person.

To use the Transfer feature to direct a call to a third party



1. Tap the **Transfer** soft key. The other party is put on hold and a dial tone sounds. The LCD indicator light flashes steadily.



2. Dial the DN number to which the call is to be transferred, or use **Personal Directory**, **Redial List**, or **Callers List** to select a number to dial.



3. When that number rings or a person answers, tap the **Transfer** soft key to connect the calling party.

To return to the original call if the transfer is incomplete



If the person called is not available, tap the line (DN) soft key (next to the LCD indicator) to reconnect to the original call.

Use Timed Reminder Recall

Use the Timed Reminder Recall feature to receive a reminder tone when a transferred call is not answered.

To use Timed Reminder Recall



1. Tap the **Transfer** soft key. The call is put on hold.



2. Dial the number to which the call is being transferred.

3. Choose one of the following to start the call timer:



- Tap the **Transfer** soft key.
- Replace the handset before the extension answers.

Note: If the transfer is complete, the recall timer stops.

If the transferred call is not answered, your telephone rings



1. Lift the handset to reconnect to the original caller.



2. Choose one of the following:
 - Tap the **Transfer** soft key and repeat the transfer.
 - If the transfer is picked up while you are on the line, press the **Goodbye** key to complete the transfer.

Use Attendant Recall

Use the Attendant Recall feature to contact an attendant during a call and to connect the call to the attendant.

To contact the attendant while on a call



1. Tap the **Attendant Recall** soft key and stay on the line until the attendant answers.



2. Press the **Goodbye** key. The caller remains connected to the attendant.

Use Call Park

Use the Call Park feature to hold temporarily (park) and retrieve a call from any telephone. Using Call Park does not tie up a line. When configured network-wide, Call Park can be used across networks. A System Park Extension can be set to automatically park most calls.

To park a call on the System Park DN or your own DN



During an active call, tap the **Park** soft key twice.

Note: By default, the call is parked on your DN, unless a System Park is enabled to automatically park calls on the system.

To park a call on a DN other than the System Park DN or your own DN



1. Tap the **Park** soft key.



2. Dial the DN where you want to park the call.



3. Tap the **Park** soft key.

To park a call using the SPRE code or FFC



or

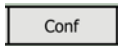

1. Choose one of the following:

- Tap the **Transfer** soft key.
- Tap the **Conference** soft key.



2. Dial the Call Park FFC.



3. To use an alternate DN from the System Park DN or your own DN, dial the DN where you want to park the call. Otherwise, proceed to Step 4.

4. Choose one of the following:

- Tap the **Transfer** soft key.
- Tap the **Conference** soft key.



or

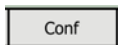

To retrieve a parked call



1. Lift the handset.



2. Tap the **Park** soft key.



3. Dial the DN where you parked the call.

Note: If a parked call is not retrieved within a specified period of time, it rings back to your telephone or to the attendant.

Record a Calling Party Number

Use the Calling Party Number feature to record a caller's number, or to charge a call to an account number, during an established call.

To record a caller's number for accounting purposes



1. Tap the **Call Party** soft key. The caller is placed on hold.



2. Dial a charge account number or the caller's number.

Note: For information on using the Charge soft key, see "Charge a call or charge a forced call" on page 104.



3. Tap the **Call Party** soft key to return to the call.

Display incoming calls

Use the Display feature to display a second incoming caller's number and name (if available) during an active call, without interfering with the call in progress.

To view the information on an incoming call while on a call in progress



1. Tap the **Display** soft key.



2. Tap the flashing line (DN) soft key. The call waiting information displays.

Note: When used with other feature soft keys, the **Display** soft key displays information associated with those feature soft keys.

Trace a Malicious call

Use the Malicious Call Trace feature to trace nuisance calls within your system.

Note: This is not a default feature. Contact your system administrator to configure this feature on your telephone.

To use Call Trace while on a call



- Tap the **Call Trace** soft key.

To use Call Trace without a Call Trace soft key



or



1. Choose one of the following:
 - Tap the **Transfer** soft key.
 - Tap the **Conference** soft key.



2. Dial the SPRE code followed by 83 or dial the Call Trace FFC to automatically reconnect.

Incoming calls

This section describes features used with incoming calls.

Activate Automatic Answerback

When the Automatic Answerback feature is active, your set automatically answers in Handsfree mode after one ring; however, calls are *not* forwarded to the voice message service.

To activate Automatic Answerback



Tap the **Automatic Answerback** soft key.

To deactivate Automatic Answerback



Tap the **Automatic Answerback** soft key again.

Activate Call Pickup

Use the Call Pickup feature to pick up calls from any telephone in the same pickup group or another pickup group.

To answer a call in your own call pickup group



1. Lift the handset.



2. Choose one of the following:
 - Tap the **Pickup** soft key.
 - Enter the Pickup Ringing Number FFC.

To answer an incoming call in another call pickup group



1. Lift the handset.
2. Tap the **Group Pickup** soft key or enter the Pickup Group FFC.
3. Dial the pickup group number of the ringing telephone.

To answer a call at a specific extension in any pickup group



1. Lift the handset.



2. Choose one of the following:

- Tap the DN **Pickup** soft key.
- Enter the Pickup Directory Number FFC.



3. Dial the DN of the telephone that is ringing (in your call pickup group). If the pickup DN or group number is invalid (an overflow burst tone sounds and the screen displays *Goodbye and try again*), press the **Goodbye** key.

Use Call Waiting

The Call Waiting feature alerts you to an incoming call by producing a tone. It also puts the current call on hold while you answer the new call.

To answer an incoming call while on another call



(Hold)

1. When the incoming call tone sounds, press the **Hold** key to put a current call on hold.

Note: If Automatic Hold is enabled, it is not necessary to press the **Hold** key.



2. Tap the **Call Waiting** soft key.

To return to the first telephone call



1. Choose one of the following:
 - Press the **Hold** key to put the second call on hold.
 - Press the **Goodbye** key to end the second call.
2. Tap the line (DN) soft key associated with the first call.

If you do not have a Call Waiting soft key



1. Press the **Goodbye** key to end the current call.
2. Tap the flashing line (DN) soft key to answer the incoming call.

While away from your desk

This section describes features to use when you are away from your desk.

Use Call Forward

Use the Call Forward feature to direct incoming calls to ring on another line (DN). If the telephone is in the process of ringing, the call cannot be forwarded.

To forward your calls or change the forward number



1. Choose one of the following:
 - Tap the **Forward** soft key.
 - Lift the handset and enter the Call Forward All Calls Activate FFC.
2. Dial the DN where you want to forward your calls.
3. Tap the **Forward** soft key.

To deactivate Call Forward

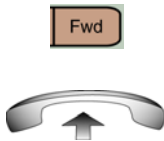

- Choose one of the following:
- Tap the **Forward** soft key.
 - Lift the handset and enter the Call Forward All Calls Deactivate FFC.

To reinstate Call Forward to the same number



Tap the **Forward** soft key twice.

Use Internal Call Forward

Use Internal Call Forward to accept only calls originating at internal DNs to ring at another DN. Calls originating outside your telephone system still ring at your telephone. Current incoming calls cannot be forwarded.

To forward internal calls



1. Choose one of the following:
 - Tap the **Internal Call Forward** soft key.
 - Lift the handset and enter the Internal Call Forward Activate FFC.
2. Dial the DN to which your internal calls will be forwarded.
3. Tap the **Internal Call Forward** soft key.

To deactivate Internal Call Forward

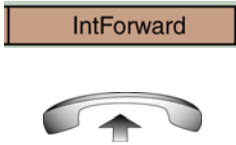

Choose one of the following:

- Tap the **Internal Call Forward** soft key.
- Lift the handset and enter the Internal Call Forward Deactivate FFC.

To reinstate Call Forward to the same number



Tap the **Internal Call Forward** soft key twice.

Use Remote Call Forward

Use the Remote Call Forward feature to forward calls (from any telephone other than your own) to any telephone.

To activate Remote Call Forward



1. Lift the handset.



2. If calling from a telephone outside the system, dial your direct system access number and wait for dial tone.



3. Dial the Remote Call Forward Activate FFC to activate the feature.



4. Dial your Station Control Password. A dial tone sounds.



5. Choose one of the following:
 - Dial your DN.
 - To forward calls to the previous call forward telephone number, press the # key. (Do not perform steps 6 and 7.)



6. Dial the number to which calls are being forwarded. If calls are forwarded to an invalid number, a fast busy signal sounds.



7. Press the # key.

To deactivate Remote Call Forward



1. Lift the handset.



2. If calling from a telephone outside the system, dial the direct system access number and wait for the dial tone.



3. Dial the Remote Call Forward Deactivate FFC.



4. Dial your Station Control Password.



5. After hearing the dial tone, dial your DN.



6. Press the # key.

Secure your telephone

Use the Electronic Lock feature to prevent others from making calls from your telephone. The Electronic Lock feature is controlled using your Station Control Password (SCPW). To change your Station Control Password, refer to “Security features” on page 19.

To lock your telephone



1. Lift the handset.



2. Dial the Electronic Lock Activate FFC.



3. Dial your Station Control Password.



4. Choose one of the following:
 - If dialing locally, press the **Goodbye** key.
 - If dialing the FCC remotely, dial your DN.

To unlock your telephone



1. Lift the handset.
2. Dial the Electronic Lock Deactivate FFC.



3. Dial your Station Control Password.



4. Choose one of the following:
 - If dialing locally, press the **Goodbye** key.
 - If dialing the FCC remotely, dial your DN.

Talk with more than one person

This section describes features that enable conversations between more than two people.

Use the Call Join feature

Use the Call Join feature to connect a call to a current active call. This creates a conference between the two callers and yourself.

To connect a call on hold (on a different line) to your current call



1. Tap the **Conference** soft key.



2. Tap the line soft key that has the number of the caller you want to connect to your current call.

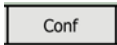

3. Tap the **Conference** soft key to add the person on hold to your conversation.

Set up a Conference call

Use the Conference feature to set up a conference call for three or six people including yourself. The number of people the conference feature supports depends on your telephone configuration.

To set up a conference call

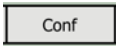

1. While on a call, tap the **Conference** soft key to place the party on hold. You receive dial tone.

2. Dial the number of the person you want to add to the conference call. You can talk privately to the person you are adding at this time.

Note: If you tap the **Directory** soft key, you can also use **Corporate Directory** or **Personal Directory**, **Redial List**, and **Callers List** to find and dial the number of the person you want to add to the conference call.



3. Tap the **Conference** soft key a second time to conference all parties together.

If the person you attempt to add to the conference is unavailable



1. Press the **Goodbye** key.



2. Tap the line (DN) soft key with the flashing status icon to return to your original call.

Use the Conferee Selectable Display and Disconnect feature

Use the Conferee Selectable Display feature to list active conferees and disconnect a conferee from the conference call.

To view active conferees



1. While on a conference call, tap the **Conferee Selectable Display** soft key to turn on the LCD indicator. Each tap changes the screen to show a different active conferee.

Note: This action has no effect on the display of other telephones involved in the conference.



2. Press the **Goodbye** key. If configured, the Conference Count Display returns an updated total count of conferees. The LCD indicator turns off.

To disconnect a conferee



1. While on a conference call, tap the **Conferee Selectable Display** soft key until the conferee you want to disconnect appears on the screen.



2. Tap the **DN** soft key on which the conference call is established.



3. Choose one of the following:
 - For a single conferee, press the **Goodbye** key. If configured, the Conference Count Display returns an updated total count of conferees. The LCD indicator turns off.
 - For multiple conferees, repeat steps 1 and 2 until all conferees are disconnected. Then press the **Goodbye** key.

Use Group Call

Use the Group Call feature to automatically call members of a predefined group, one at a time, until they all answer.

To call group members



1. Lift the handset.

GrpCl

2. Tap the **Group Call** soft key or enter the Group Call FFC.
 - The feature automatically calls all group members. The icon flashes until all members answer.
 - The telephone numbers of the group members appear on the display as they answer. When the last person answers, the Group Call indicator lights steadily.
 - When parties in your group are on a conference call or another group call, they are not connected to your group call.
 - After everyone in the group has answered, only the person who made the group call can put the call on hold.

To answer a group call



1. Lift the handset. Note the following about notification tones:
 - If you are on a call and receive three ten-second tones, a group call is on your current extension.
 - If you are on a call on another line when a group call is made, you receive a long tone through the handset or speaker.
 - If you are already on a conference call or another group call, you do not receive notification of a group call.

To end a group call



Press the **Goodbye** key.

Note: When the person who made the group call disconnects, the call terminates for all members of the group. However, the members of the group call can disconnect from the call without affecting other members on the call.

Work without interruption

This section describes features that provide uninterrupted work time.

Activate Make Set Busy

Use the Make Set Busy feature to make your telephone appear busy to all callers.

To activate Make Set Busy



Choose one of the following:

- Tap the **Make Set Busy** soft key.
- Lift the handset and enter the Make Set Busy Activate FFC.

To deactivate Make Set Busy



Choose one of the following:

- Tap the **Make Set Busy** soft key a second time to deactivate the feature.
- Lift the handset and enter the Make Set Busy Deactivate FFC.

Additional call features

Contact your system administrator to determine if the following call features are available on your telephone.

Use AutoDial Transfer

Use the AutoDial Transfer feature to transmit digits through your AutoDial soft key to the Central Office after a Trunk Switchhook Flash. You must be on a Central Office/Exchange (CO) trunk call from or to a Central Office (CO) that offers Centrex or exchange line-type features.

To use AutoDial Transfer when picking up an incoming trunk call



1. Tap the **Centrex Switchhook Line Flash** soft key and wait for interrupted dial tone.



2. Tap the **AutoDial** soft key to call the number desired.



3. Press the **Goodbye** key to end the call.

Use the Buzz signal

Use the Buzz feature to notify another person of a call, a visitor, or a request. Two telephones linked together enable one person to signal the other. The person signaled hears a buzz.

To buzz the telephone linked to your telephone



Tap the **Buzz** soft key. The telephone linked to your telephone buzzes as long as you hold the soft key.

Use Call Page Connect to make an announcement

Use the Call Page Connect feature to make an announcement over a paging system.

Note: A **Page** soft key on an attendant console overrides and disconnects the telephones. The telephones must re-access the page trunk.

To connect to Call Page



1. Lift the handset.



2. Dial the Page Trunk Access Code to complete the connection to the page system.

3. Make your announcement.



4. Press the **Goodbye** key.

Use Centrex/Exchange Line Switchhook Flash

Use the Centrex/Exchange Line Switchhook Flash feature during an established call to use a Centrex service, such as Call Transfer or Three-Way Calling.

To use Centrex/Exchange Line Switchhook Flash



1. While on a call, tap the **Centrex Line Switchhook Flash** soft key. A special dial tone sounds.



2. Dial the codes for your custom Centrex feature.



3. Press the **Goodbye** key to end the call.

Charge a call or charge a forced call

Use the Call Charge feature to charge a call to a specific account. The Forced Charge feature charges long-distance calls from a telephone restricted to local calls.

To charge a local or long-distance call to an account before you dial



1. Lift the handset.



2. Tap the **Charge** soft key or dial the Call Detail Recording FFC.



3. Dial the charge account number.



4. When the dial tone sounds, dial the number.

To charge a call in progress



or

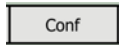

- Choose one of the following:
 - Tap the **Transfer** soft key.
 - Tap the **Conference** soft key.



- Choose one of the following:
 - Tap the **Charge** soft key.
 - Dial the Call Detail Recording FFC.



3. Dial the charge account number.



- Tap the line (DN) soft key to return to the call.



To charge a call to an account when you transfer a call



1. Tap the **Transfer** soft key. The call is placed on hold.



2. Choose one of the following:
 - Tap the **Charge** soft key
 - Dial the Call Detail Recording FFC.



3. Dial the charge account number.



4. After the dial tone, dial the number to where the call is to be transferred.



5. Tap the **Transfer** soft key when you hear the telephone ring.



Note: You can talk privately to the person at the transfer number before you tap the Transfer soft key.

To charge a call to an account when you add someone to a conference call

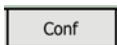

1. Tap the **Conference** soft key. The call is placed on hold.

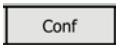

2. Choose one of the following:
 - Tap the **Charge** soft key.
 - Dial the Call Detail Recording FFC.

3. Dial the charge account number.

4. Dial the number of the person you want to add to the conference.

5. Tap the **Conference** soft key.

Use Enhanced Override

Use the Enhanced Override feature to override an active call after you attempt a Forced Camp-on (see “Use Forced Camp-on feature” on page 108). Use Enhanced Override to make a simple call or a consultation call, such as placing a call on hold and calling another party.

To use Enhanced Override



You receive a busy signal after dialing a telephone number.



1. Choose one of the following:
 - Tap the **Override** soft key.
 - Enter the Override FFC to initiate a Forced Camp-on.

If either person on the call disconnects at this time, you receive an overflow (fast busy/engaged) signal.



2. Choose one of the following:
 - Tap the **Override** soft key again.
 - Enter the Override FFC again.

The other two persons on the call receive an override tone and a conference call is established between the three of you. If anyone disconnects, the other two persons remain connected.



3. To terminate the call, press the **Goodbye** key.

Use Forced Camp-on feature

Use the Forced Camp-on feature to automatically ring another telephone (internal or external) immediately after that telephone disconnects from its current call.

To use Forced Camp-on



You receive a busy signal after dialing a telephone number.



EnhOvr



1. Choose one of the following:
 - Tap the **Override** soft key.
 - Enter the Override FFC, to initiate a Forced Camp-on.

Note: The person you called receives a tone. You receive a ring/ringback or a busy/engaged signal, depending on the options chosen. You are now camped-on to the number you dialed.

2. Hang up the telephone.
3. When the person you called finishes the existing call, your telephone automatically dials the number and both telephones ring.

Answering a call camped-on to your extension



When your telephone rings, lift the handset.

Note: You can program your telephone for either Camp-on or Call Waiting, but not both.

Override a busy signal

Use the Override feature to override a busy signal and interrupt another call.

To override a busy/engaged signal



1. Dial a telephone number and receive a busy signal.



2. Choose one of the following:
 - Tap the **Override** soft key.
 - Enter the Override FFC. The people in the targeted call receive a tone for approximately one second. After Override feature joins you to their call, a short tone repeats every 16 seconds.



3. To terminate the call, press the **Goodbye** key.

Use Privacy Release

Use the Privacy Release feature to enable one or more people who share your DN to join a call.

To use Privacy Release in an established state



Tap the **Privacy Release** soft key during a call. Parties join the call by tapping the shared number (DN) soft key on their telephones (Multiple Appearance DN feature).

Use Radio Page

Use the Radio Page feature to page a person and stay on the line until that person answers. The paged person answers the call after entering a special Page Meet-me code from any telephone.

To use Automatic Preselection (Meet-me page)



1. Lift the handset.



2. Dial the Radio Paging Access FFC. The paging tone sounds (two beeps followed by a dial tone).



3. Dial the number of the party you want to page. After dialing, the ringback tone sounds.

Note: The paged person can use any telephone to enter a Radio Paging Answer FFC, plus their own DN number.

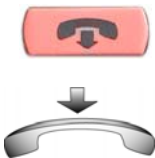

4. If your call goes unanswered for a preset time period, and a 15-second high-pitched tone sounds followed by silence, press the **Goodbye** key or replace the handset.

To use Automatic Post selection

The called party is either busy on the telephone or away from the telephone. To page the called party, there is no need to redial the number of the called party.

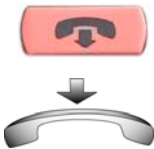

1. Tap the **Radio Page** soft key. A special dial tone sounds.
2. Dial the Radio Paging Access FFC. The ringback tone sounds.
Note: The paged parties can use any telephone to enter a Radio Paging Answer FFC, plus their own DN number.
3. If your call goes unanswered for a preset time period, and a 15-second high-pitched tone sounds followed by silence, press the **Goodbye** key or replace the handset.

To answer a Radio Page

If you carry a Radio Pager, a page indicates that someone dialed your DN. If the Radio Page system is set up to function in Meet-me mode, you can answer the page call from any telephone.



1. Lift the handset.



2. Dial the Radio Page Answer FFC. The paging tone sounds.



3. Dial your own DN to connect to the paging caller. If the caller has hung up, a steady high-pitched (Number Unavailable) tone sounds.

Use Voice Call

Use the Voice Call feature to page another person or make an announcement through someone else's telephone speaker.

To make a voice call



1. Lift the handset.



2. Tap the **Voice Call** soft key and make the announcement.



3. Press the **Goodbye** key.

To respond to a voice call



Your telephone rings once and the caller's voice transmits through your speaker. Lift the handset.

Additional features

Personal Directory

Use the Personal Directory feature to create and store up to 100 directory entries. A Personal Directory entry can contain:

- last name (up to 24 characters)
- first name (up to 24 characters)
- telephone numbers (up to 31 characters)

To use Personal Directory, tap the **Directory** soft key and select **Personal Directory**.

To add an entry



1. Tap the **AddNew** soft key.

Note: If the message “Directory is full” appears, one or more entries must be deleted to add a new entry.



2. Tap the **Next** soft key.



3. Use the dialpad to enter the telephone number.



4. Tap the **Next** soft key.



5. Use the dialpad to enter the name.

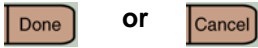

6. Do one of the following:
 - Tap the **Done** soft key to save the new entry.
 - Tap the **Cancel** soft key to return to the **Add** screen.

To edit an entry

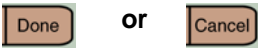

1. Press the **Up/Down** navigation keys to scroll and highlight the desired entry.
2. Tap the **Edit** soft key and perform your edits.
3. Choose one of the following:
 - Tap the **Done** soft key to save the changes.
 - Tap the **Cancel** soft key.

To delete an entry



1. Press the **Up/Down** navigation keys to scroll and highlight the desired entry.



2. Tap the **Delete** soft key.



or



3. Choose one of the following:
 - Tap the **Confirm** soft key.
 - Tap the **Cancel** soft key.

To search for an entry



1. Press the **Up/Down** navigation keys to scroll and highlight the desired entry.



or



2. Choose one of the following:
 - Tap the **Dial** soft key to dial the resulting number.
 - Tap the **Cancel** soft key to exit without dialing.

Callers List

The Callers List feature logs all incoming calls. Callers List can store up to 100 entries in the list. When the list is full, the system overwrites the oldest entry. Use the Callers List feature to review missed calls and to dial calls. The Callers List contains:

- the caller's last and first name (if available)
- the DN of the caller
- the time/date of the call
- the number of times the caller calls

Entries in Callers List are sorted according to the time calls are received.

Note: Calling Party Name Display (CPND) is affected depending on the preferred name match option. If preferred name match is on, the CPND appears according to your settings. If the preferred name match option is off, the CPND appears according to the system settings.

To access the Callers List, tap the **Directory** soft key and select **Callers List**.

Note: If password control is enabled, enter your SCPW at the prompt.

To dial an entry



1. Press the **Up/Down** navigation keys to scroll and highlight the desired entry.



2. Tap the **Dial** soft key.

To delete an entry



1. Press the **Up/Down** navigation keys to scroll and highlight the desired entry.



2. Tap the **Delete** soft key.



or



3. Choose one of the following:
 - Tap the **Confirm** soft key.
 - Tap the **Cancel** soft key.

To delete the entire Callers List



1. Tap the **Delete** soft key.

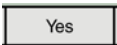

or

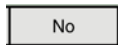

2. Choose one of the following:
 - **Yes** to delete entire Callers List.
 - **No** to return to the previous screen.

Redial List

The Redial List feature logs all outgoing calls. Redial List can store up to 20 entries in the list. When the list is full, the system overwrites the oldest entry. Use the Redial List feature to review calls made, and to redial previously dialed calls. The Redial List contains:

- last and first names of the dialed party (if available)
- DN of the dialed party
- time/date of the last dialed occurrence

Entries in the Redial List are sorted according to the time the calls are received.

Note: Calling Party Name Display (CPND) is affected depending on the preferred name match option. If preferred name match is on, the CPND appears according to your settings. If the preferred name match option is off, the CPND appears according to the system settings.

To access Redial List, tap the **Directory** soft key and select **Redial List**.

Note: If password control has been enabled, enter your SCPW at the prompt.

To dial an entry



1. Press the **Up/Down** navigation keys to scroll and highlight the desired entry.



2. Tap the **Dial** soft key.

To delete an entry



1. Press the **Up/Down** navigation keys to scroll and highlight the desired entry.



2. Tap the **Delete** soft key.



or



3. Choose one of the following:
 - Tap the **Confirm** soft key.
 - Tap the **Cancel** soft key.

To delete the entire Redial List



1. Tap the **Delete** soft key.

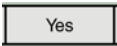

or

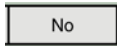

2. Choose one of the following:
 - **Yes** to delete entire Redial List.
 - **No** to return to the previous screen.

Virtual Office

When you are away from your office telephone, use the Virtual Office feature to transfer calls, and all of your office telephone features, to a remote telephone.

Note 1: Consult your system administrator to verify if the Virtual Office feature is available for your use.

Note 2: When designated as the office telephone, the IP Phone 2007 can be activated for Virtual Office by an IP Phone 2002, IP Phone 2004, IP Phone 2006, IP Softphone 2050, or another IP Phone 2007.

Note 3: When an IP Phone 2002 is logged in to an IP Phone 2004, IP Phone 2006, IP Phone 2007, or an IP Softphone 2050 using Virtual Office, feature soft keys 4, 5, and the Shift key are not available to it.

Note 4: A Virtual Office login from an IP Phone 2007 to an IP Phone 2002 or IP Softphone 2050 can be blocked in certain situations. Consult your system administrator.

Virtual Office login

To activate Virtual Office on your office telephone from your remote telephone



1. Tap the **Services** soft key.



2. Press the **Up/Down** navigation keys to scroll and highlight **Virtual Office Login**.



3. Tap the **Select** soft key.



4. At the prompt, enter your User ID.



5. Tap the **Select** soft key.



6. At the prompt, enter the home Station Control Password (SCPW).

Note 1: If the User ID is not found locally, the message “Locating Remote Server” displays.

Note 2: After three failed login attempts, wait one hour before attempting to log in again, or contact your system administrator to reset your password. For more information, see “Security features” on page 19.

A successful login transfers all the features, time, date, and tones to your remote telephone from your office telephone.

Virtual Office on your office telephone



When activated for Virtual Office by a remote telephone, your office telephone is logged out and is no longer operational.

A “Logged Out” message displays on your telephone alerting you that it is being used for Virtual Office.

To regain operation of a telephone being used for Virtual Office

Choose one of the following:

1. To completely disconnect your office telephone from the remote telephone:
 - a. Tap the **Home** soft key.
 - b. Enter your User ID and password (this logs the office telephone back on to your office network).
2. To use your office telephone as the remote telephone for Virtual Office, tap the **Virtual** soft key to log in to another IP Phone.



Virtual Office logout

 Services

1. Tap the **Services** soft key.



2. Press the **Up/Down** navigation keys to scroll and highlight **Virtual Office Logout**.

 Select

3. Tap the **Select** soft key.

Troubleshoot Virtual Office

When you use Virtual Office, error messages can display on-screen. Table 5 lists error messages and actions to correct the causes.

Table 5: Troubleshoot Virtual Office (Part 1 of 3)

| Displayed Message | Probable Cause | Actions |
|-------------------|--|---|
| Busy, try again | Remote IP Phone is active (not idle). | Wait for remote IP Phone to become idle and try again. |
| | ACD is logged in. | Log out of ACD IP Phone before initiating Virtual Office from another IP Phone. |
| | Make-Set-Busy is inactive on ACD IP Phone. | Set Make-Set-Busy active on ACD IP Phone. |

Table 5: Troubleshoot Virtual Office (Part 2 of 3)

| Displayed Message | Probable Cause | Actions |
|--------------------------|--|--|
| Invalid ID (1) | Incorrect User ID entered. | Enter correct User ID. |
| | User ID is not in Gatekeeper database. | Notify system administrator. |
| Invalid ID (2) | Incorrect User ID entered. | Enter correct User ID. |
| Invalid ID (3) | Incorrect User ID entered. | Enter correct User ID. |
| | User ID in Gatekeeper database points to originating Call Server. | Notify system administrator. |
| Locked from Login | Three failed attempts to enter the correct Station Control Password. | Wait one hour for the lock to clear automatically, or notify system administrator to clear lock. |
| Permission Denied (1) | Remote telephone has no Station Control Password. | Notify system administrator. |
| Permission Denied (3) | Incorrect User ID entered. | Enter correct User ID. |
| | Remote telephone has no Station Control Password. | Notify system administrator. |

Table 5: Troubleshoot Virtual Office (Part 3 of 3)

| Displayed Message | Probable Cause | Actions |
|---------------------------|---|--|
| Permission Denied (4) | Incorrect User ID entered. | Enter correct User ID. |
| | Attempt to log in to a remote IP Phone 2002 or IP Softphone 2050 from an IP Phone 2007 (some restrictions apply). | Go to an IP Phone 2002 or IP Softphone 2050 and try again, or consult your local system administrator. |
| Permission Denied (5) | Incorrect User ID entered. | Enter correct User ID. |
| | Remote telephone does not have VOUA Class of Service. | Notify system administrator. |
| Permission Denied (6) | Incorrect User ID entered. | Enter correct User ID. |
| | Incorrect Station Control Password entered. | Select Retry , and try again with the correct Station Control Password. |
| Server Unreachable (1) | Network problem. | Notify system administrator, if problem persists. |
| Server Unreachable (2) | Network problem. | Notify system administrator, if problem persists. |

Media Gateway 1000B

The Media Gateway 1000B (MG 1000B) telephone can operate in Normal or Local Mode.

Normal Mode

The telephone registers with the Main Office and receives telephone services from the Main Office. At any time during Normal Mode, you can check local mode functionality (make and receive calls) by enabling Local Mode and returning to Normal Mode. After testing, you can return to Normal Mode by using the *Resume Normal Mode* command or by waiting for ten minutes.

Local Mode

If the WAN connection goes down, the IP Phone loses communication with the Main Office Terminal Proxy Server (TPS). The IP Phone then registers with the MG 1000B and receives telephone services from the MG 1000B. Features such as Personal Directory, Redial List, and Callers List are not available when operating in Local Mode. When in Local Mode, the telephone displays "LOCAL MODE".

Test Local Mode

Use Test Local Mode to check local mode functionality (make and receive telephone calls). This is useful when provisioning has changed for an IP Phone on an MG 1000B Controller.



1. Tap the **Services** soft key.



2. Press the **Up/Down** navigation keys to scroll and highlight **Test Local Mode**.



3. Tap the **Select** soft key (the telephone resets and registers to the branch office).

Resume Normal Mode

Use the Resume Normal Mode command to return to Normal Mode after testing survival functionality.

Note: If the Resume Normal Mode command is not performed after testing, the telephone automatically returns to Normal Mode in ten minutes.



1. Tap the **Services** soft key.



2. Press the **Up/Down** navigation keys to scroll and highlight **Resume Normal Mode**.



3. Tap the **Select** soft key (the telephone registers back to the Main Office).

Troubleshoot MG 1000B

When using MG 1000B, error messages can display on your screen. Table 6 lists error messages and actions to correct the causes.

Table 6: Troubleshoot MG 1000B (Part 1 of 2)

| Display Message | Probable Cause | Actions |
|-----------------|------------------|---|
| Local Mode | Test Local mode. | Tap the Services soft key, and then select Resume Normal Mode . |
| | Network problem. | Contact system administrator if problem persists. |

Table 6: Troubleshoot MG 1000B (Part 2 of 2)

| Display Message | Probable Cause | Actions |
|------------------------------|--|------------------------------|
| Local Mode Invalid ID (1) | Gatekeeper unable to find endpoint from Branch User ID. | Notify system administrator. |
| Local Mode Invalid ID (2) | Branch User ID not found in any equipped Terminal Number (TN). | Notify system administrator. |

Hospitality features

Hospitality features are intended for hotel operations.

Set Automatic Wake-Up

Use the Automatic Wake-Up feature to receive a timed reminder call. From your telephone, you can program the system to automatically place a call to yourself at a predetermined time. When you answer the call, recorded music plays for up to 30 seconds, followed by a prerecorded announcement or the attendant.

To enter the time for an Automatic Wake-Up call



1. Lift the handset.



2. Dial the Automatic Wake-Up Request FFC.



3. Dial the Automatic Wake-Up time in a 24-hour time format (hhmm). A tone sounds to confirm your entered time.

Note: In a 24-hour time format, 7:30 a.m. is entered as 0730; 9:45 p.m. is entered as 2145.



4. Press the **Goodbye** key.

To deactivate an Automatic Wake-Up call



1. Lift the handset.



2. Dial the Automatic Wake-Up Quit FFC.



3. Press the **Goodbye** key.

To verify the time for the Automatic Wake-Up call



1. Lift the handset.



2. Dial the Automatic Wake-Up Verify FFC.



3. Dial the Automatic Wake-Up time in a 24-hour time format (hhmm). If your query matches the preset time, a confirmation tone sounds.

Note: In a 24-hour time format, 7:30 a.m. is entered as 0730; 9:45 p.m. is 2145.



4. Press the **Goodbye** key.

Activate Message Registration

Use the Message Registration feature to read, change, or reset meters that log your hotel telephone calls.

To read meters



1. Tap the **Message Registration** soft key.



2. Dial the room Directory Number (DN).



3. Tap the **Message Registration** soft key.

To change a meter



1. Tap the **Message Registration** soft key.



2. Dial the room DN number.



3. Dial the correct meter count.



4. Press the * key.



5. Tap the **Message Registration** soft key.

To reset a meter to zero



1. Tap the **Message Registration** soft key.



2. Dial the room Directory Number (DN).



3. Press the * key.



4. Tap the **Message Registration** soft key.

Use Maid Identification

Use the Maid Identification feature to track the cleaning status of rooms. The maid enters the information from the telephone in each room.

To enter cleaning status



1. Tap the **Room Status** soft key.



2. Dial the Directory Number (DN) of the room for which the cleaning status is being changed.



3. Dial one of the following cleaning status codes:

1 = Cleaning requested

2 = Cleaning in progress

3 = Room cleaned

4 = Room passed inspection

5 = Room failed inspection

6 = Cleaning skipped

7 = Not for sale

The interrupted dial tone sounds.



4. Press the * key.



5. Dial the Maid ID. If you dial the wrong Maid ID, press the * key and redial the ID.



6. Tap the **Room Status** soft key.

Display Room Status

Use the Room Status feature to print the status of a room using the Display Module.

To read the status of a room



1. Tap the **Room Status** soft key.



2. Dial the Directory Number (DN) of the room. The DN displays followed by a two-digit code.

The first digit indicates the occupancy status:

0 = Room vacant

1 = Room occupied

The second digit indicates the cleaning status of the room:

1 = Cleaning requested

2 = Cleaning in progress

3 = Room cleaned

4 = Room passed inspection

5 = Room failed inspection

6 = Cleaning skipped

7 = Not for sale



3. Tap the **Room Status** soft key.

To change the status of a room



1. Tap the **Room Status** soft key.



2. Dial the Directory Number (DN) of the room. The DN displays followed by a two-digit code.

The first digit indicates the occupancy status:

0 = Room vacant

1 = Room occupied

The second digit indicates the cleaning status of the room:

1 = Cleaning requested

2 = Cleaning in progress

3 = Room cleaned

4 = Room passed inspection

5 = Room failed inspection

6 = Cleaning skipped

7 = Not for sale



3. Using the dialpad, enter the new status code for the room. A three-digit code appears. The first digit indicates the occupancy status, the second is the old cleaning status, and the third is the new status.

RMK

4. Tap the **Room Status** soft key.

External server applications

Use External Server Applications to access a variety of applications directly from your IP Phone 2007. For more information about the External Server Applications, consult the *Nortel IP Phone External Server Applications User Guide*.

Flexible Feature Codes (FFC)

Use Table 7 to track the FFCs assigned by your system administrator.

Table 7: Flexible Feature Codes

| FFC | Feature | FFC | Feature |
|-----|--------------------------------------|-----|---------------------------------|
| | Automatic Wake-Up Activate | | Malicious Call Trace |
| | Automatic Wake-Up Deactivate | | Override |
| | Automatic Wake-Up Verify | | Pickup Directory Number |
| | Call Detail Recording Charge Account | | Pickup Group |
| | Call Forward All Calls Activate | | Pickup Ringing Number |
| | Call Forward All Calls Deactivate | | Radio Paging Access |
| | Call Park | | Radio Paging Answer |
| | Electronic Lock Activate | | Remote Call Forward Activate |
| | Electronic Lock Deactivate | | Remote Call Forward Deactivate |
| | Group Call | | Ring Again Activate |
| | Internal Call Forward Activate | | Ring Again Deactivate |
| | Internal Call Forward Deactivate | | Station Control Password Change |
| | Make Set Busy Activate | | Virtual Office Terminal Log Off |
| | Make Set Busy Deactivate | | Virtual Office Terminal Log On |

Regulatory and safety information

Table 8 lists EMC compliance for various jurisdictions, while Table 9 lists compliance with Safety standards

Table 8: EMC

| Jurisdiction | Standard | Description |
|---------------------------|-------------------------|---|
| United States | FCC CFR 47 Part 15 | Class B Emissions: FCC Rules for Radio Frequency Devices (see Notes 1a and 1b) |
| Canada | ICES-003 | Class B Emissions: Interference — Causing Equipment Standard: Digital Apparatus |
| Australia/ New Zealand | AS/NZS 3548 CISPR 22 | Class B Emissions: Information technology equipment — Radio disturbance |
| European Community | EN 55022/ CISPR 22 | Class B Emissions: Information technology equipment — Radio disturbance |
| | EN 55024 | Information technology equipment — Immunity characteristics — Limits and methods of measurement |
| | EN 61000-3-2 | Limits for harmonic current emissions (equipment input current \leq 16 A per phase) |
| | EN 61000-3-3 | Limitation of voltage fluctuations and flicker in low-voltage supply systems for equipment with rated current \leq 16 A |

Note 1: This equipment has been tested and found to comply with the limits for a Class B digital device, pursuant to part 15 of the FCC Rules. These limits are designed to provide reasonable protection against harmful interference in a residential installation.

This equipment generates, uses, and can radiate radio frequency energy and, if not installed and used in accordance with the instructions, may cause harmful interference to radio communications. However, there is no guarantee that interference

will not occur in a particular installation. If this equipment does cause harmful interference to radio or television reception, which can be determined by turning the equipment off and on, the user is encouraged to try to correct the interference by one or more of the following measures:

- Reorient or relocate the receiving antenna.
- Increase the separation between the equipment and receiver.
- Connect the equipment into an outlet on a circuit different from that to which the receiver is connected.
- Consult the dealer or an experienced radio/TV technician for help.

Note 2: The user should not make changes or modifications not expressly approved by Nortel. Any such changes could void the user's authority to operate the equipment.

Table 9: Safety

| Jurisdiction | Standard | Description |
|-----------------------|----------------------|---|
| United States | UL 60950 3rd Edition | Safety of Information Technology Equipment |
| Canada | CSA 60950-00 | Safety of Information Technology Equipment |
| European Community | EN 60950-1 | ITE equipment - Safety - Part 1: General requirements |
| Australia/New Zealand | AS/NZS 60950.1:2003 | Safety of Information Technology Equipment |

Other Safety Approvals: IEC 60950-1: ITE equipment - Safety - Part 1: General requirements

Other

US/Canada: Hearing Aid Compatibility (HAC) as per FCC Part 68

Australia: AS/ACIF S004: Voice Frequency Performance Requirements for Customer Equipment

This equipment complies with the CE Marking requirements. 

Index

A

About the IP Phone 2007 11
Answer a call 76
Attendant Recall 80
AutoDial 69
AutoDial Transfer 102
Automatic Answerback 85
Automatic Wake-Up 131

B

Basic features 12
Buzz signal 103

C

Calibrate the touch panel 19
Call features and Flexible Feature Codes 19
Call Forward 89
Call Join 95
Call Page Connect 103
Call Park 80
Call Pickup 85
Call timer 55
Call Waiting 87
Callers List 66
Calling Party Number 82
Camp-on, Forced 74, 108
Centrex/Exchange Line Switch-hook Flash 104
Change feature key labels 56
Charge a call or charge a forced call 104

Conferee Selectable Display and Disconnect 97
Conference call 96
Configure area code setup 52
Configure call log options 48
Configure Callers List log 48
Configure Local Options 28
Configure Name Display format 59
Configure New Call indication 50
Configure options 37
Configure Preferred Name Match 51
Connect the components 26
Contrast adjustment 43
Contrast and Brightness 30
Corporate Directory 64

D

Date/Time format 45
Directory applications 64
Display diagnostics 46
Display incoming calls 83

E

Electronic Lock 93
Enhanced Override 107
Enter and edit text 23
External server applications 138

F

Flexible Feature Codes (FFCs) 139

Forced Camp-on 74

G

Goodbye key 13

Group Call 98

H

Handsfree dialing 62

Headset key 14

Hold key 13

Hospitality features 131

Hot Line 74

Hot Line feature 74

I

Intercom call 74

Internal Call Forward 90

L

Language display 44

Last Number Redial 72

Local Area Network (LAN) 11

Local Diagnostics 28

Local Dialpad Tone 46

Local Mode 128

M

Maid Identification 134

Make Set Busy 101

Malicious Call Trace 83

Media Gateway 1000B 128

Meet-me page 111

Message Registration 133

Message waiting indicator 14

Mute key 14

N

Navigation keys 14

Network Configuration 28

Normal Mode 128

O

Off-hook dialing 61

Onhook Default Path 55

On-hook dialing 61

Override a busy signal 110

P

Personal Directory 66

Place a call on hold 77

Predial feature 68

Preferences 34

Privacy Release 110

R

Radio Page 111

Record a Calling Party Number 82

Redial List 67

Remote Call Forward 91

Resume Normal Mode 129

Ring Again 70

Ring type 54

Ringback/ring tone 109

Room Status 135

S

Secure your telephone 93

Security features 19

Set information 47
Speaker key 14
Speed Call 72
System Speed Call 73

T

Telephone display 14
Telephone Options 38
Test Local Mode 128
Timed Reminder Recall 78
Touch panel 18
 Cleaning 19
 Setup 29
Transfer a call 77

U

USB Devices 32
USB keyboard
 function keys 25

V

Virtual Office 122
Virtual Office login 122
Virtual Office logout 125
Virtual Office on your Office telephone 124
Virtual Office on your office telephone 124
Voice Call 113
Volume adjustment 39
Volume control bar 13

Nortel Communication Server 1000

IP Phone 2007

User Guide

Copyright © 2006 Nortel Networks. All rights reserved.

The Information in this document is subject to change without notice. The statements, configurations, technical data, and recommendations in this document are believed to be accurate and reliable, but are presented without express or implied warranty. Users must take full responsibility for their applications of any products specified in this document. The information in this document is proprietary to Nortel Networks.

Nortel, Nortel (Logo), the Globemark, SL-1, Meridian 1, and Succession are trademarks of Nortel Networks.

Publication Number: NN-10300-017

Document Release: Preliminary 2.03

Date: February 2006

Produced in Canada



www.nortel.com