



PowerTouch 350
User Guide



Contents

Introduction.....	1
Unpacking the phone	3
Description	4
Installation.....	6
Installing on a desk	6
Installing on a wall	9
Checking your telephone	11
Basic features	12
Making a basic call	12
Making volume adjustments.....	13
Personalizing your phone.....	14
Locking the Directory.....	15
Callers List	16
Dialing from the Callers List	17
Editing a number in the Callers List before dialing	17
Copying from the Callers List	18
Deleting from the Callers List	18
Directory	20
Adding to the Directory	20
Finding items in the Directory	22
Changing a Directory item	22
Dialing Directory items	23
Deleting Directory items	23

Advanced features.....	25
Predialing a number.....	25
Redialing a number.....	25
Dialing without the handset.....	25
Dialing with a Live dial pad.....	26
Timing a call.....	26
Using Flash.....	26
Privacy/Extension in use.....	26
Services.....	27
Activating a service.....	27
Deleting a service.....	28
Prompts and indicators.....	29
Display prompts.....	29
Indicators.....	30
Helpful hints.....	31
Warranty and repairs.....	33
Cleaning the display.....	33
General inquiries.....	33
Regulatory information.....	33
Index.....	34

Introduction



Your telephone has gone modular! Now you can change features simply by removing one module and sliding in another.

Let the display be your guide

Follow the display on the module for instructions to use features and handle calls. Your telephone has an 8-line display, with enlarged numbers.

Store the numbers of your friends right in the phone

Once you've added numbers to the Directory, calling is easy. Instead of hunting for your phone book, look in the Directory and dial the number with the touch of a key.

Don't stop what you're doing to talk

If you need both hands to do something, use the handsfree key. Then just talk normally on the speakerphone while you go on with your task.

See if you have a message †

You've been expecting a call but you had to run an errand. When you get back, look at your phone: if the light is flashing, a caller has left a message for you.

† Requires voice message service (light indicator service may not be available in all areas).

See your telephone company about subscribed services.

Don't worry if your line's tied up* ††

Your telephone display lets you know who that second caller is while you're on the phone.

Recognize a private number*

You know your caller has a private number before you even answer because your telephone has a special ring for private callers. The display also shows you that the number is private.

Identify callers by preferred name*

The phone company knows her as Mrs. Smith, but you call her "Mom". If you've got her number and name in the Directory, you'll see "Mom" on the display whenever she calls.

See who's called*

You're out. Check the Callers List to see who's called, then call back at your convenience. Or, if you're busy, check the display to see who's calling. Then decide if you want to answer.

* Requires Caller ID service.

†† Requires Caller ID on Call Waiting service (not available in all areas).

Unpacking the phone

After unpacking, keep the boxes.
Check to see that you have these parts:

If any part is missing, contact the
outlet where you got the telephone.

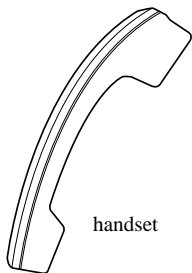

handset

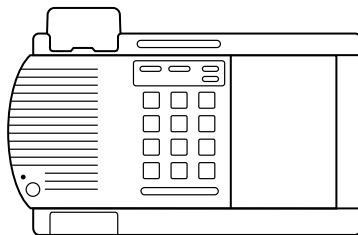

base

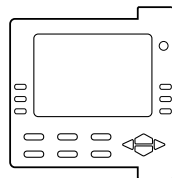

module



2 line cords



handset cord

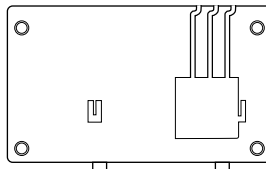

stand



number card
and lens



language plate



regulatory sheet

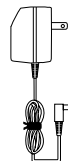

power adaptor

Description - Base

Handsfree/Mute activates the speaker and microphone so you can listen and talk without lifting the handset (page 25).

Hold puts the call on hold (page 12).

Light shows when you have calls or messages (page 30).

Flash allows you to connect to network features, such as call waiting (page 26).

Goodbye always ends an active call (page 12).

Volume lets you adjust the receiver, speaker, and ringer volume (page 13, 29, and 31).

Options lets you access eight options to customize your telephone (page 14).

Description - Module

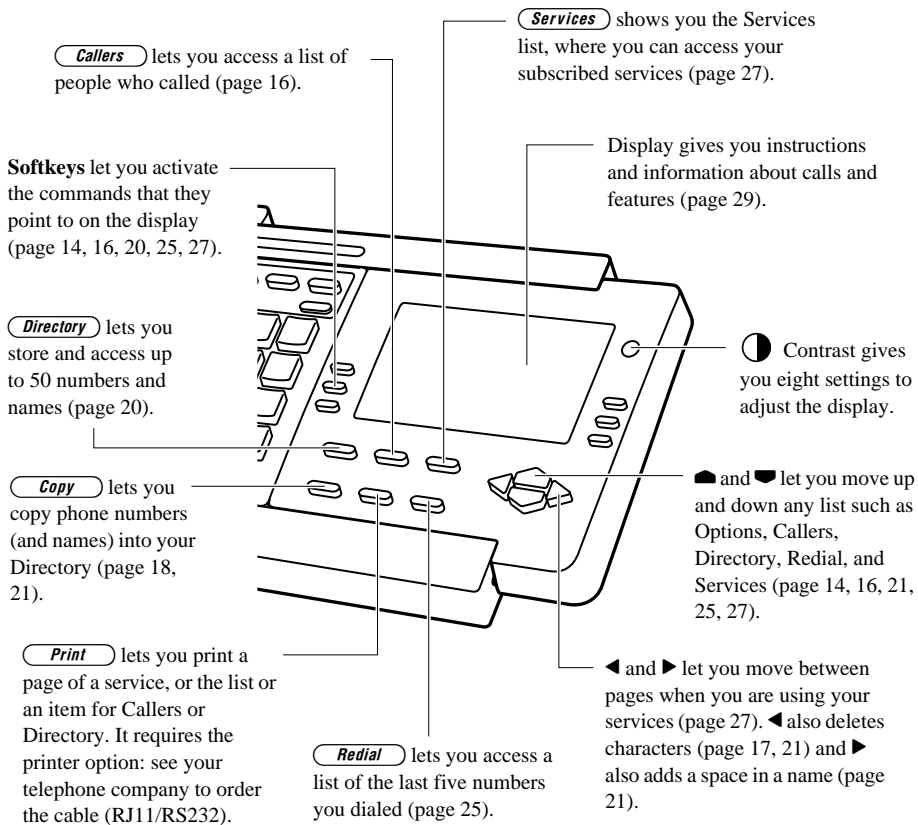

Installation

Note: Before inserting or removing a module, unplug all cords to the telephone. The telephone will not work without a module.

Installing on a desk

1. Insert the module

Remove the clip from the connector. Slide the module all the way into the base from the right-hand side.

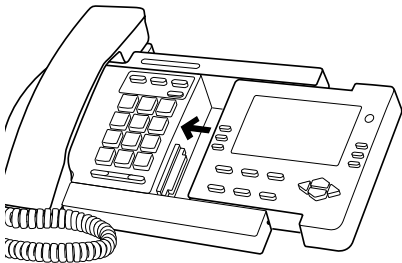

2. Connect the handset cord

Turn the telephone over. Plug one end of the handset cord into the jack marked with  on the bottom of the telephone. Then, route the handset cord down through the channel below.

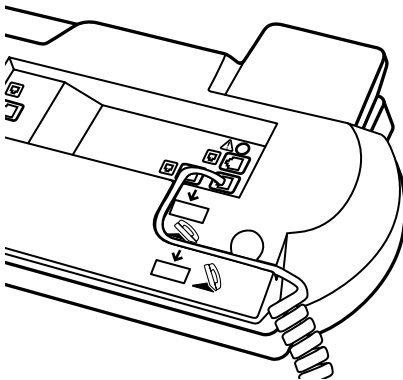

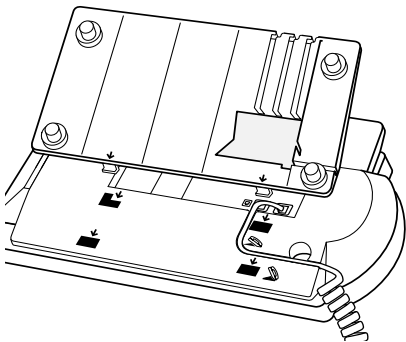

3. Lower the stand into the slots

Hold the stand so that the square opening is on the lower right.



For a high viewing angle:

Lower the stand so that the two tabs fit into the lower slots on the bottom of the telephone (marked with ).

For a low viewing angle: Lower the stand so that the two tabs fit into the upper slots on the bottom of the telephone (marked with ).

4. Lock the stand into place

Press down hard on the top edge of the stand until the locking tabs click.

Note: To remove the stand: Reverse the process in steps 3 and 4. With one hand holding the phone and the other hand holding the stand, pull them apart, increasing pressure steadily until the stand pops off.

5. Connect the line cord

Plug one end of the long (6 ft) line cord into the jack next to the handset jack on the bottom of the telephone, marked with **1** .

6. Connect the fax machine, modem or answering machine (optional)

Plug one end of the second line cord (not supplied) into the jack above the handset jack on the bottom of the telephone, marked with **2** .

7. Attach the power adaptor

Plug the power adaptor into the power jack on the bottom of the telephone, marked with **A** .

8. Route the cords

Route the line cords and power adaptor cord through the channels in the stand.

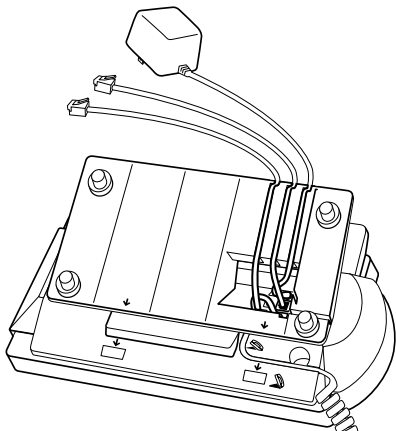

9. Plug in the cords

Plug the power adaptor into a wall outlet.

Plug one line cord into one telephone wall jack. Plug the second line cord into the fax machine, modem, or answering machine.

10. Attach the handset

Plug the other end of the handset cord into the handset and place the handset on the telephone.

11. Insert the number card

Write your telephone number on the card and place it into the slot on the telephone. Bend the clear plastic lens into the slot, over the number card.



Note: Keep the plastic lens away from small children.

12. Insert the language plate

Snap the plate over the keys above the dial pad.

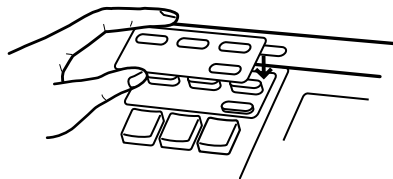

Installing on the wall

1. Insert the module

Remove the clip from the connector. Slide the module all the way into the base from the right-hand side.

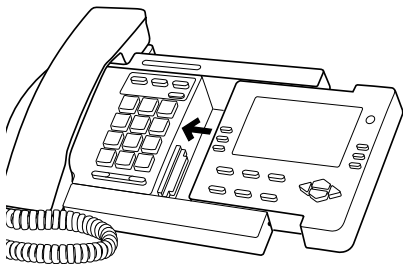

2. Connect the handset cord

Turn the telephone over. Plug one end of the handset cord into the jack marked with  on the bottom of the telephone. Then, route the handset cord down through the channel below.

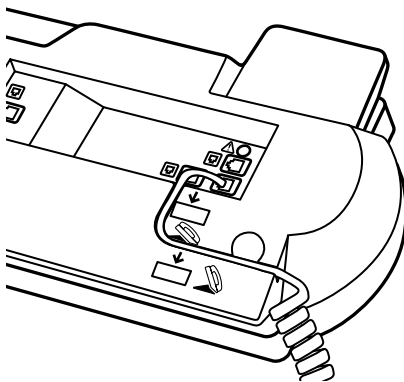

3. Connect the line cord

Plug one end of the short (8 in.) line cord into the jack next to the handset jack on the bottom of the telephone, marked with .

4. Connect the fax machine, modem or answering machine (optional)

Plug one end of the second line cord (not supplied) into the jack above the handset jack on the bottom of the telephone, marked with 2 \blacksquare .

5. Attach the power adaptor

Plug the power adaptor into the power jack on the bottom of the telephone, marked with \blacktriangle .

6. Plug in the cords

Plug the power adaptor into a wall outlet.

Plug the short line cord into the telephone wall jack. Plug the second line cord into the fax machine, modem, or answering machine.

7. Mount the telephone

Press the telephone against the wall-mount plate until the hooks on the plate align with the wall-mount slots on the telephone. Slide the telephone down until it is secure.

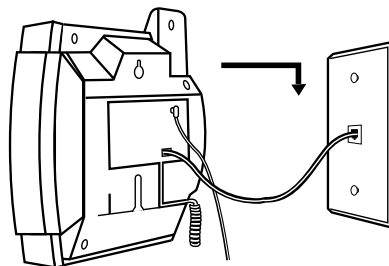

8. Attach the handset

Plug the other end of the handset cord into the handset and place the handset on the telephone.

9. Insert the number card

Write your telephone number on the card and place it into the slot on the telephone. Bend the clear plastic lens into the slot, over the number card.

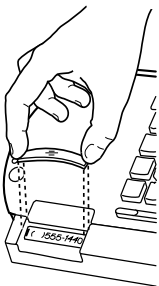

Note: Keep the plastic lens away from small children.

10. Insert the language plate

Snap the plate over the keys above the dial pad.

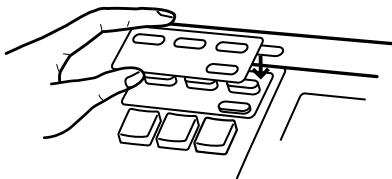

Checking your telephone

Whenever the telephone has been without power for a long period of time, the display asks you to select a language when power returns. Follow the directions on the display to select one of the languages.

If you've missed the prompt for language, don't worry. See page 14 for another way to change the language.

The telephone also runs a test to ensure that the line cord is connected. If the test fails, the display prompts you to check the phone cord (■).

You can now use your telephone. But read on to learn more about your telephone's special features. If you want to customize your phone, see Personalizing your phone on page 14.

Basic features



Making a basic call

For other ways of handling calls (including predialing), see page 25.

To dial a number

1. Lift the handset.
2. Enter the number using the dial pad.

To answer a call

1. Lift the handset.

To end a call

1. Hang up the handset or press **(Goodbye)**.

To place a call on hold

1. Make or answer a call.
2. Press **(Hold)**.
3. Hang up the handset.
4. Lift the handset of this phone or an extension phone to retrieve the call.

Note: If a call is held for more than 15 minutes, it is automatically reconnected. If the handset is off the telephone, the caller can hear you again. If the handset is on the telephone, the call is released.

Making volume adjustments

Adjusting the ringer volume

Without lifting the handset, press the left side of  until **Ringer is OFF** appears on the display. To turn the ringer on or up, press the right side of the volume bar without lifting the handset. The telephone rings while you adjust the volume so you can hear how loud it is. The new volume level is saved automatically.

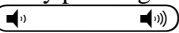

Adjusting the receiver volume

When you are on a call, you can turn the volume of what you hear up or down by pressing the right or left side of . The receiver volume returns to normal when the handset is put back on the telephone.

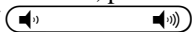

Adjusting the speaker volume

When you are on Handsfree, press the left or right side of  to turn the speaker volume up or down. If you hold either end of the key down, you can scroll through all the volume settings. The speaker volume setting stays at the new level between calls.



Personalizing your phone

Your telephone has eight options to personalize your telephone. The display shows four options at a time. To preview the entire list, keep pressing  and .

To select an option

1. Press  (recessed key).
2. Press the option number (for example, press  to set the dial pad mode).

OR

Press  or  to scroll through the list, one option at a time. Then press the **SHOW** softkey to check the option setting.

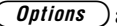
3. Press the appropriate softkeys to change the setting.
4. Press the **DONE** softkey.
5. Press  or  at any time to leave the list.

1. Display language

Change to the other language (Spanish or English).

2. Time and date

Enter the time and date. The setting is updated with each incoming call.

3. Ring tone

Choose one of three ring tones.

4. Call timer

Turn the timer on or off. When on, it times each call automatically (if a service is not active).

5. Dial pad mode

Turn Live dial pad on or off. When on, the telephone automatically dials out any number you press on the dial pad. When off, you can predial or view numbers on the display before you dial them.

6. Clear Message Waiting

If you get the **Message Waiting** prompt on the display when there aren't any messages, turn the display prompt and the telephone light off.

7. Area code

Enter up to three area codes so that calls can be dialed from the Callers List without the area code.

8. Callers List mode

Select the type of calls to be logged in the Callers List. Choose between no calls, all calls, or unanswered calls.

Display icons



You are in the Options list.

Locking the Directory

Once you've accumulated a lot of items in the Directory, you can lock it so that items won't be accidentally erased.

Note: You cannot change or add items in a locked Directory.

To lock the Directory

1. Press **Options**.
2. Press **Hold**.
3. Press **¥** . The display shows that the Directory is locked.

To unlock the Directory

1. Press **Options**.
2. Press **Hold**.
3. Press **£** . The display shows that the Directory is unlocked.

Callers List

Your telephone logs up to 25 incoming calls which are stored in the Callers List.

Note: The Callers List remains empty until you receive calls AND until you subscribe to calling line identification service from your local telephone company.

The Callers List tells you who called while you were out or unavailable, and lets you dial the callers back from the list.

If the number matches a number that you've programmed with a name in the Directory, the Callers List will show that name.

From the Options list, the Callers List can be programmed to record all incoming calls, no calls, or only unanswered calls. Press **Options**, **i**, and follow the instructions on the display.

To view the Callers List

1. Press **Callers** to see the Callers List heading.
2. When there are new callers, press **▼** to see the first new caller in the list.

OR

Press the **Resume** softkey to see the last caller you viewed the last time you were in the Callers List.

3. Press **▶** or **◀** to move between callers.
4. Press **Callers**, the **Quit** softkey, or **Goodbye** at any time to leave the Callers List.

Note: **Goodbye** also hangs up if you're on a call.

Dialing from the Callers List

If you call a number from the Callers List and you don't get connected, you may have to edit the number (for example, the number may be long distance and you may have to add "1").

To dial from the Callers List

1. Press **Callers**.
2. Use **▼** and **▲** to find the caller.
3. Press the **DIAL** softkey or the Handsfree key, or lift the handset.

Note: If you dial any numbers after the call connects, those numbers won't appear on the display.

Note: When you finish the call, you return to the same number in the Callers List.

Changing a number in the Callers List before dialing

If you frequently have to delete an area code to dial a number, enter the area code in the Options list. Press **Options**, **▶**, and follow the instructions on the display. After you do this, that area code will appear in brackets, but won't be dialed out.

To edit a number in the Callers List

1. Press **Callers**.
2. Press **▼** until you find the caller you wish to call.
3. If you just want to add digits, you can skip this step. If you want to delete digits first, press the **EDITNUM** softkey to begin editing.
4. Use the dial pad to add digits. Press the **REMOVE** softkey or **▶** to erase one digit to the right of the cursor. Press the **BACKSPACE** softkey or **◀** to erase one digit to the left of the cursor.

Caution: Callers List does not save changes. If you plan to call the number again, copy it to the Directory before dialing it (see the next procedure).

5. Press the **DIAL** softkey or the Handsfree key, or lift the handset to make the call.

Copying from the Callers List

To copy to the Directory

1. Press **Callers**.
2. Press **▼** until you find the caller you wish to copy.
3. If it requires editing, press the **EditNum** softkey and follow the instructions in the procedure before this one.
4. Press **Copy**. If a name was displayed, skip steps 5 and 6.

5. If no name is displayed, you are prompted to enter one. If you don't want to save a name, go to step 6. To enter a name, use the dial pad. (The letters are on the keys. For special characters, see the chart on page 21.)
6. Press the **SAVE** softkey.

Deleting from the Callers List

To delete one caller

1. Press **Callers**.
2. Press **▼** until you find the caller you wish to delete.
3. Press the **Delete** softkey.
4. Press the **Delete** softkey again to confirm the action.

To delete all callers

1. Press **Callers**.
2. Press the **DeleteList** softkey.
3. Press the **Delete** softkey to confirm.

Icons in the Callers List



You are in the Callers List.



You answered the call when it came in.



You did not answer the call when it came in.



You were on another call when this call came in.

✓ You have returned the call from the Callers List.



The area code has been stripped off.

4× The party called four times.

Directory

The Directory lets you store up to 50 names and numbers in alphabetical order so that you can dial numbers directly from the Directory. The Directory sorts the names by the first character.

For consistency, always enter your Directory names in the same order (last name first, or first name first). If you don't enter a name, the item is sorted by the telephone number. All telephone number items are at the beginning of the Directory.

Adding to the Directory

To add a name and number

1. Press **Directory** if you are not already in the Directory.
2. Press the **AddNew** softkey.
3. Enter the telephone number using the dial pad. The number can have up to 24 digits.
4. Press the **SAVE** softkey.
5. If you don't want to save a name, go to step 6. Press the key with the desired letter until that letter appears on the display. (The letters are on the keys. For special characters, see the chart on page 21.) The name can have up to 16 characters, including spaces.

If the number includes external access codes or personal identification numbers, enter a pause between the two numbers. Press the **PAUSE** softkey for a pause. (The **PAUSE** softkey appears after you've entered the first digit of the number.) If **Flash** is required for a custom calling feature, press **Flash** at the appropriate place in the number. You can press these keys without activating these functions on the telephone.

Press the **NextSpace** softkey or ► to move to the next letter or add a space.

For example, to enter Ruth: press

, ►, i i , ►, i , ►,

Note: You don't have to press ► or the **NextSpace** softkey if the next letter is on a different key.

Press the **ChangeCase** softkey to switch between upper and lower case.

Press the **BackSpace** softkey or ◀ to erase a character.

6. Press the **SAVE** softkey. The display shows the new item.

Chart for special characters

The following characters aren't shown on your dial pad keys.

Key	Character
	& ' () , - .
Q	Q
Æ	Z

To copy from the display

1. When a number is on the display, press **Copy**.
If a name was on the display, skip steps 2 and 3.
2. If no name is displayed, you are prompted to enter one. If you don't want to save a name, go to step 3. To enter a name, use the dial pad. (The letters are on the keys. For special characters, see the chart on this page.)
3. Press the **SAVE** softkey.

To copy from Redial

1. Press **Redial**.
2. Press ◀ or ▶ to find the number you want to copy.
3. Press **Copy**.
If a name was on the display, skip steps 4 and 5.

4. If no name is displayed, you are prompted to enter one. If you don't want to save a name, go to step 5. To enter a name, use the dial pad. (The letters are on the keys. For special characters, see the chart on page 21.)
5. Press the **SAVE** softkey.

Finding items in the Directory

To find items in the Directory

- Press **Directory** to see the Directory list heading.
 - Press **▼** to scroll down and **▲** to scroll up the Directory, one listing at a time.
 - Press and hold **▼** or **▲** to continuously scroll down or up the Directory.
 - Press the appropriate dial pad key to see the listings that start with a particular letter. (For example, **6** takes you to the first 'J' listing; use **7** for the second 'J' listing; **8** takes you to the first 'K' listing.)
- Press the **Change** softkey to edit a listing (the number, the name, or both).
 - If the display shows... after the number, it means the number is longer than the display.
 - Press **Directory**, the **Quit** softkey, or **Goodbye** to get out of the Directory.

Note: **Goodbye** also hangs up if you're on a call.

Changing a Directory item

To change a Directory item

1. Press **Directory**.
2. Find the name and number you want to change by pressing the first letter of the name or **▼**, or **▲**.
3. Press the **Change** softkey.
4. To skip the number, go to step 5. Use the **Backspace** softkey or **◀** to erase digits. Use the dial pad to add digits.
5. Press the **Save** softkey.

6. If you don't want to change the name, go to step 7. To change the name, press the **BackSpace** softkey or ◀ to erase letters. Use the dial pad and the **NextSpace** softkey or ▶ to add letters. (The letters are on the keys. For special characters, see the chart on page 21.)

Press the **ChangeCase** softkey to switch between upper and lower case.

7. Press the **SAVE** softkey.

Dialing Directory items

To dial from the Directory

1. Press **Directory**.
2. Find the name and number you want to call by pressing the first letter of the name or ◀, or ▶.
3. Press the Handsfree key or the **DIAL** softkey, or lift the handset.

Note: If you dial any numbers after the call connects, those numbers won't appear on the display.

4. Press **Goodbye** or hang up to end the call.

Note: When you finish the call, you are no longer in the Directory.

Deleting Directory items

To delete individual items

1. Press **Directory**.
2. Find the name and number you want to delete by pressing the first letter of the name or ◀, or ▶.
3. Press the **Delete** softkey.
4. Press the **Delete** softkey again to confirm.

The display shows the next listing in the Directory.

5. Press **Directory**, the **Quit** softkey, or **Goodbye** to get out of the Directory.

Note: **Goodbye** also hangs up if you're on a call.

To delete all items

1. Press **Directory**.
2. Press the **DeleteList** softkey.
3. Press the **Delete** softkey to confirm the action.
4. Press **Directory**, the **Quit** softkey, or **Goodbye** to get out of the Directory.

Note: **Goodbye** also hangs up if you're on a call.

Display icons



You are in the Directory.



You pressed **Flash** or **Flash** has been programmed into a number.



You pressed the **Pause** softkey or a pause (which can be up to 3 seconds) has been programmed into a number.

Advanced features

Predialing a number

Predial lets you view the number first, before you dial it. It helps prevent dialing errors. Predial does not work when the Live dial pad option is on (see page 14).

To predial a number

1. Enter the number using the dial pad. Use the **BackSpace** softkey or **◀** to correct errors.
2. Lift the handset, or press the **DIAL** softkey or Handsfree key.

Redialing a number

Redial shows you a list of the last five numbers you called.

To redial a number

1. Press **Redial**.
2. Press **▼** or **▶** to find the number.
3. Lift the handset, or press the **DIAL** softkey or Handsfree key.

If you dial any numbers after the call connects, those numbers won't appear on the display.

To delete a redial number

1. Press **Redial**.
2. Press **▼** or **▶** to find the number.
3. Press the **Delete** softkey twice.

Display icons

R You are in the Redial list.

Dialing without the handset

With Handsfree you don't have to interrupt the task at hand to talk on the telephone. You can also use the Mute feature to talk to someone else in the room without the caller hearing.

To dial using Handsfree

1. Press the Handsfree key.
2. Enter the number.

3. If you want to talk to someone else in the room without the caller hearing you, press the Handsfree key again. The Handsfree light flashes. You can still listen to the caller.

Each time you press the Handsfree key, you switch between Handsfree and Mute.

Dialing with a Live dial pad

You can make the telephone dial out and go on Handsfree as soon as you press a dial pad key. Do this by turning Live dial pad on: press **Options**, , and follow the instructions on the display.

To dial with a Live dial pad

1. Enter the number using the dial pad. The number is dialed automatically and the call goes on Handsfree.
2. Whenever you want privacy, lift the handset.

Timing a call

You can turn the call timer on, if you want to automatically time the length of your calls, or you can turn it off. Press **Options**, , and follow the instructions on the display. The timer begins counting when you answer, or 5 seconds after you dial. The timer does not run when a service is active.

Using Flash

You use **Flash** mainly for subscribed services, such as call waiting and three-way calling. Follow the procedures given to you by your telephone company when you subscribe to these features. Wherever it says to press the hook-switch or receiver button, press **Flash** instead.

Privacy/Extension in use

Extension in use appears on the display when someone uses an extension telephone. The light remains on until the other person hangs up.

Services

The large display on your telephone offers you the advantages of full-screen services, much like an automatic banking machine. You can subscribe to enhanced telephone company features and services such as home banking, catalog shopping, movie libraries, and restaurant guides. You can also subscribe to telephone network services such as network voice mail.

The Services list shows you the services that you subscribe to. Before you can select a service, you must load it into your telephone. For information on loading a service, please contact your telephone company or service provider.

Some services may be available by dialing them directly, and do not need to appear in your Services list. You can store the number for this kind of service in your Directory.

Note: Some telephone features (such as call timer) may be disabled when you are using a service.

Activating a service

To activate a service

1. Press **Services**.
2. Press **▲** and **▶** to move the cursor to the service you want.
3. Press the **Select** softkey to activate the service next to the cursor.
4. Once you have connected to the service, follow the instructions.
5. After a Services session, press the **Quit** softkey or **Goodbye** to leave the list.

Deleting a service

You may be able to delete a service when you no longer use it or when you want to replace it.

To delete a service

1. Press **Services**.
2. Press **Left Arrow** and **Right Arrow** to move the cursor to the service you want.
3. Press the **Delete** softkey.
4. If you change your mind, press the **Restore** softkey.
5. Press the **Quit** softkey or **Goodbye** to leave the list.

Note: You may not be able to delete some services.

Display icons



You are in the Services list.



Press **Right Arrow** or **Left Arrow** for more information.



Service information is being downloaded to your telephone.

Prompts and indicators

Display prompts

Your telephone display gives you instructions and information. If you want to know what to do about a particular display prompt, look it up here. The prompts are listed in alphabetical order.

For other helpful hints, see page 31.

Check phone cord

A line cord (📞) is not connected properly.

Directory is full

You are in a full Directory or trying to copy an item to a full Directory. Delete an item that you no longer use before adding or copying an item.

Directory is empty

You have pressed **Directory** and the list is empty. Press the **AddNew** softkey to add items.

In English

Español

The telephone now has power. Press a softkey to change the language for the display.

Message Waiting

Check for new messages at your Voice Mail center. Press ▶ to see other display prompts.

Private name or

Private number

The caller has requested that the name (or number) not be shown. Your telephone rings differently for private calls.

Redial List is empty

You have pressed **Redial** and the list is empty. Or, you have just deleted all items in the list.

Ringer is OFF

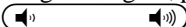
You can't hear incoming calls. To turn the ringer on again, press the right side of .

Unknown name or
Unknown number

The telephone company is unable to provide the name or number of the caller.

XX New callers

XX new calls have been added to the Callers List since you last checked it. Press **Callers** to access the list.

Indicators

The telephone light and Handsfree/Mute light let you know the status of calls and messages. The tables below show what the lights mean and also what the display shows in different situations.

Handsfree/Mute light

Feature	Light
Call is on Handsfree	Handsfree/Mute light is on.
Handsfree call is muted	Handsfree/Mute light flashes. Display shows Microphone muted .

Telephone light

Feature	Light
Call is on hold	Light flashes. Display shows Call is on hold .
Extension is in use	Light is on. Display shows Extension in use .
Message is waiting	Light flashes. Display shows Message Waiting .
Visual ringing	Light flashes while ringing. Display shows name and number (if available).

If you've checked your messages and the display still shows that there is a message waiting, turn off the prompt and the telephone light using the Options list. Press **Options**, , and follow the instructions on the display.

After you check your messages, it takes a few seconds for the prompt and light to turn off.

Helpful hints

Callers are not identified on the display.

Let the telephone ring at least twice before answering. Make sure you subscribe to calling line identification services from your local telephone company.

The display is blank and ringer volume is very low.

Make sure the power adaptor is plugged in a working electrical outlet.

You cannot dial a number in the Callers List.

If the number of the caller is unknown, you cannot return the call.

Or, the number may require an area code. Press the **EditNum** softkey to edit the number, then press the **DIAL** softkey.

You cannot hear a caller or be heard.

Increase the receiver or speaker volume. Make sure the handset cord is inserted securely into the jack. If the Handsfree light is flashing, the call is muted: press the Handsfree key.

The telephone wobbles.

Make sure the cords are routed properly through the stand, as indicated in the Installation section. Check that the stand has been properly snapped in.

The display works but you can't hear a dial tone.

Make sure the line cord is connected in the appropriate jack. If the problem persists, have your wall jack checked: the wiring may need to be repaired.

The cursor doesn't move when you're adding to the Directory.

The name or number may be too long. Names can be no longer than 16 characters and numbers can be no longer than 24 characters.

The display is in the alternate language.

You can change to the other language by pressing (**Options**), , and the appropriate softkey.

You cannot place a call.

This telephone requires tone service.

The display is blank.

Your telephone provides basic telephone service during a power failure. You can use the dial pad and receive calls, but the other keys and the display do not work until power returns.

The time and date are wrong.

If the power has been out, the next incoming call will reset the time and date. (You must subscribe to calling line identification service.) To manually reset the time and date, press **Options**, , and follow the instructions on the display.

The ringer sounds different.

When a call comes in from a private name or number, the ringer uses a special tone.

Numbers don't show on the display.

If you dial using the Directory, Callers List, or Redial, numbers you press on the dial pad will not appear on the display. (This keeps passwords from appearing on the display.) If you dial using the dial pad, every number you press will appear.

The Redial list shows more than the number you dialed.

If you dial using the dial pad, the Redial list stores all digits you dial, even those you dial after the call connects. If you want just the number to be stored, dial using the Directory or Callers List.

My voice mail password shows up in the Redial list.

If you dial your voice mail number using the dial pad, all digits you dial, including your password, are stored in the Redial list. Delete the number in your Redial list.

To keep your voice mail password a secret, program the telephone number for your voice mail service into the Directory. Do not program your password. Then, always dial the voice mail number using the Directory. When you dial your password, it won't show up in the Redial list.

What is a softkey?

There are three keys on the left and right side of the display. They do different things, depending on the label next to them on the display.

Warranty and repairs

When you ship your telephone to a Aastra Telecom Service Center, you are responsible for shipping charges.

Cleaning the display

Use only a soft cloth soaked in isopropyl alcohol to clean the display.

Warning: Do NOT use a dry cloth: it might scratch the surface. Do NOT use ketone, acetone, toluene, or xylene: they may damage the coating.

General inquiries

If you've read the guide and you have questions, call 1-800-574-1611 in the USA and in Canada.

Regulatory information

The Load Number (LN) for your telephone is 8. The Ringer Equivalence number (REN) is 0.7B. Please see the bottom of your telephone or the Regulations sheet for more regulatory and safety information.

Index

- • • • • • • • • • • • • • • •
- Alternate language **14**
- Answering a call **12**
- Answering machine,
 - connecting **7, 9**
- Area code **15**
- Arrow keys **5**

- Backspace key **5**

- Call is on hold **30**
- Call timer **14, 26**
- Callers key **5**
- Callers List **16–19**
 - Answer mode **15**
 - Changing an item **17**
 - Copying to the Directory **18**
 - Deleting items **18**
 - Dialing a number **17**
 - Dialing problems **31**
 - Editing items **17**
 - Icons **19**
 - Viewing items **16**
- Calls on hold **12**
- Changing
 - a Callers item **17**
 - a Directory item **22**
- Chart for special characters **21**
- Check phone cord **29**
- Cleaning the display **33**
- Contrast key **5**
- Copy key **5**
- Cords, routing **8**
- Customer service **33**

- Date and time **14**
 - Problems **32**
- Deleting items
 - Callers List **18**
 - Directory **23**
 - Redial number **25**
 - Services **28**

- Desk mounting **6**
- Dial again See Redial
- Dialing a number **12**
 - Problems **31**
- Directory **20–24**
 - Adding items **20**
 - Changing items **22**
 - Copying from Redial **21**
 - Deleting items **23, 24**
 - Dialing a number **23**
 - Finding items **22**
 - Locking and unlocking **15**
 - Problems **31**
- Directory full **29**
- Directory is empty **29**
- Directory key **5**
- Display **5**
 - Cleaning **33**
 - Enlarged numbers **1**
 - Icons **15, 19, 24, 25, 28**
 - Language **14**
 - Problems **31**
 - Prompts list **29**
- Display keys See Softkeys
- Display services **27**
- Down-arrow key **5**
- Enlarged numbers **1**
- Erasing items
 - Callers List **18**
 - Directory **23**
 - Redial number **25**
 - Services **28**
- Extension in use **26, 30**
- Fax machine, connecting **7, 9**
- Finding items
 - Callers List **16**
 - Directory **22**
 - Redial list **25**
- Flash, in a Directory number **20**
- Flash key **4, 26**
 - Overlay **8, 11**
- Goodbye key **4**
 - Overlay **8, 11**

Handset, connecting **8, 10**
Handset cord, connecting **6, 9**
Handsfree calls **25, 26**
Handsfree light **30**
Handsfree/Mute key **4**
Helpful hints **31–32**
Hold key **4**
 Overlay **8, 11**
Holding a call **12**

Icons **15, 19, 24, 25, 28**
In English **29**
Inquiries **33**
Installation **6–11**
 Module **6, 9**
 Stand **7**

Key description **4–5**

Language choice **14, 31**
Language plate **8, 11**
Left-arrow key **5**
Lights on the phone **4, 30**

Line cord, connecting **7, 9**
List of parts **3**
Live dial pad **14, 26**
Load number **33**
Locking the Directory **15**

Message Waiting **14, 29, 30**
Microphone muted **30**
Modem, connecting **7, 9**
Module, installing **6, 9**
Mounting the phone
 on a desk **6**
 on a wall **9**
Mute key See Handsfree key

Names in the Directory **20**
New Callers **30**
Number card **8, 10**
Numbers in the Directory **20**

Options 14

- Area code **15**
- Call timer **14**
- Callers List mode **15**
- Dial pad mode **14**
- Display language **14**
- Message Waiting prompt **14**
- Ring tone **14**
- Time and date **14**

Options key 4

- Overlay **8, 11**

Parts list 3

- Password, voice mail **32**
- Pause, in a Directory number **20**
- Plugging in the cords **8, 10**
- Power adaptor, connecting **7, 10**
- Predialing **25**
- Print key **5**
- Printer option **5**
- Private name **29**
- Private number **29**

Problems 31–32

- Callers List **31**
- Dialing **31**
- Directory **31**
- Display **31**
- Display language **31**
- Redial list **32**
- Ring tone **32**
- Time and date **32**
- Voice mail security **32**
- Volume **31**

Prompts 29, 30

Receiver volume 13

- Problems **31**

Redial 25

- Deleting items **25**
- Problems **32**

Redial key 5

- Redial List is empty **29**
- Regulatory information **33**
- Removing the stand **7**
- Repair information **33**

- Right-arrow key **5**
- Ring tone **14**
 - Problems **32**
- Ringer Equivalence number **33**
- Ringer is OFF **29**
- Ringer volume **13**
- Security
 - Directory items **15**
 - Voice mail **32**
- Service centers **33**
- Services **27**
 - Deleting **28**
 - Selecting **27**
- Services key **5**
- Softkeys **5, 32**
- Speaker volume **13**
 - Problems **31**
- Special characters **21**
- Stand
 - Connecting **7**
 - Removing **7**
 - Routing cords **8**
- Subscribed services **2, 26, 27**
- Symbols See Display icons
- Symbols See Icons
- Telephone
 - Description **4, 5**
 - Lights **4, 30**
 - Unpacking **3**
- Time and date **14**
 - Problems **32**
- Timing calls **26**
- Troubleshooting **31–32**
- Unknown name **29**
- Unknown number **29**
- Unpacking the phone **3**
- Up-arrow key **5**
- Viewing items
 - Callers List **16**
 - Directory **22**
 - Redial list **25**

Voice mail password **32**

Volume

Problems **31**

Receiver **13**

Ringer **13**

Speaker **13**

Volume key **4**

Wall mounting **9**

Warning, cleaning the
display **33**